

Precision Agriculture

Site Specific Management



Variable Rate Applications

Map-based VRA

sensors - positioning, pressure/flow,
ground speed

controller

actuators

Sensor-based VRA

sensors - soil/plant, pressure/flow,
ground speed

controller

actuators

Table 1 – The three major components of any VRA system

Mapping versus Real Time Approach

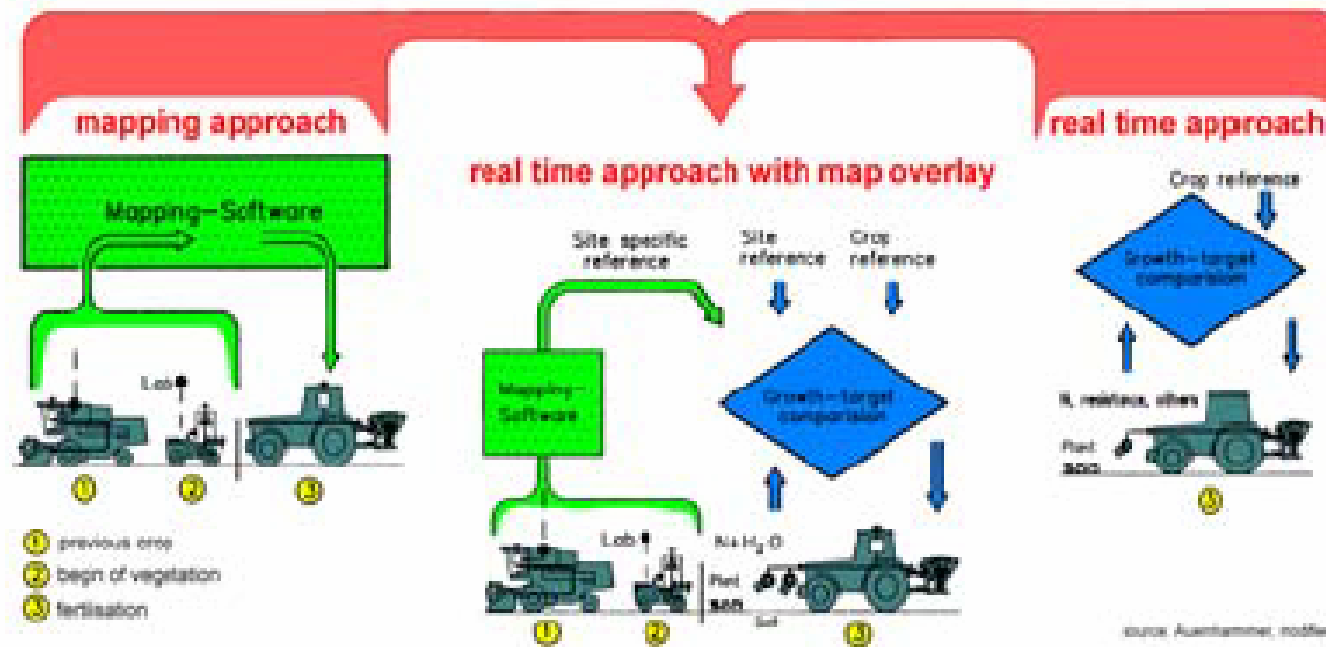

Manual mapping system

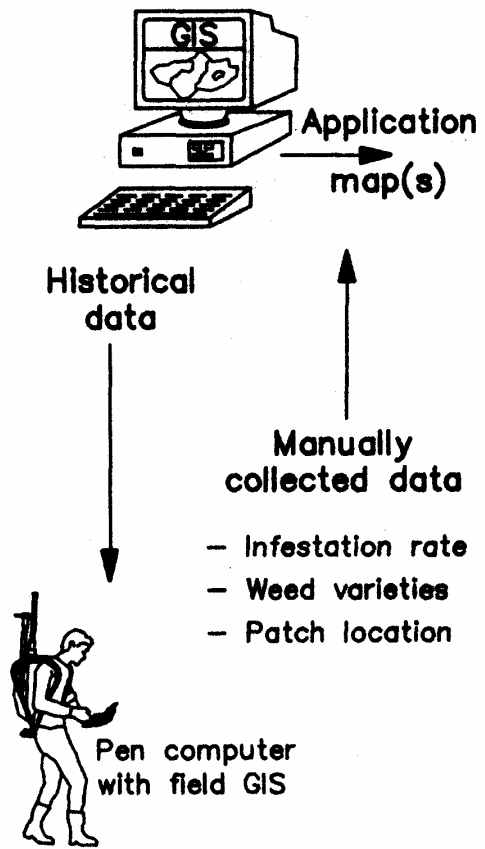

Plant coverage system

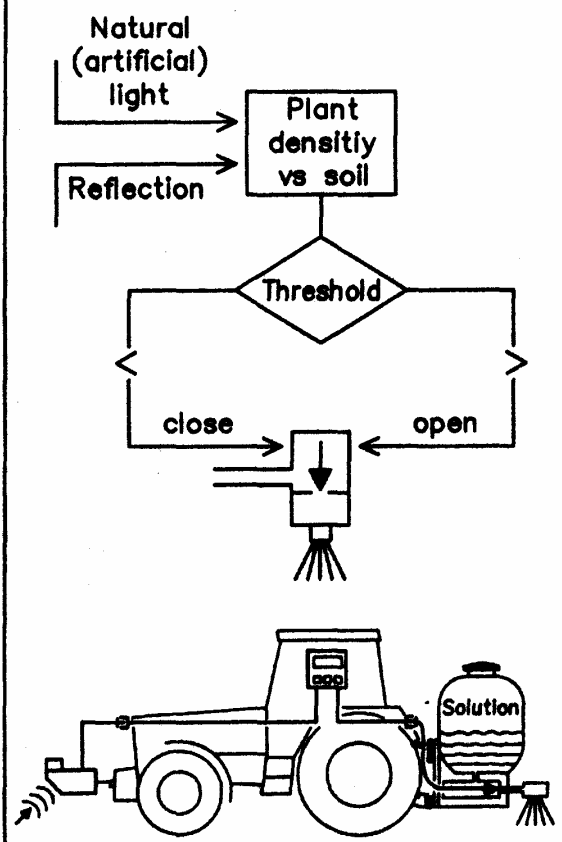
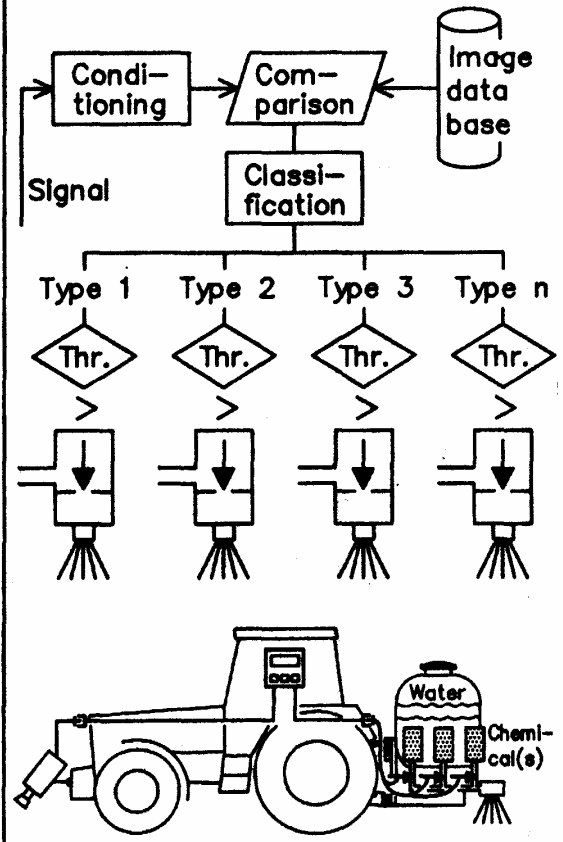

Image processing system



Sensor Based / On-the-go Fertiliser Application



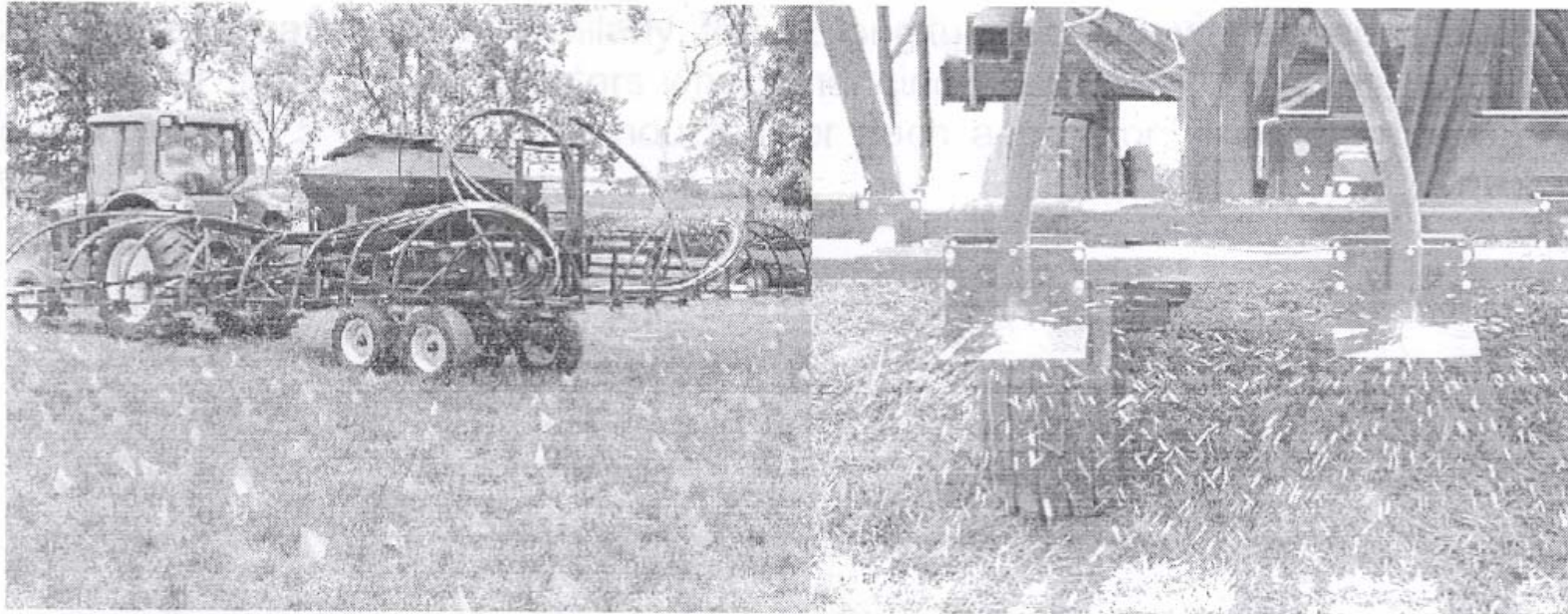

Figure 1. Gandy Orbit-Air granular applicator and deflector.

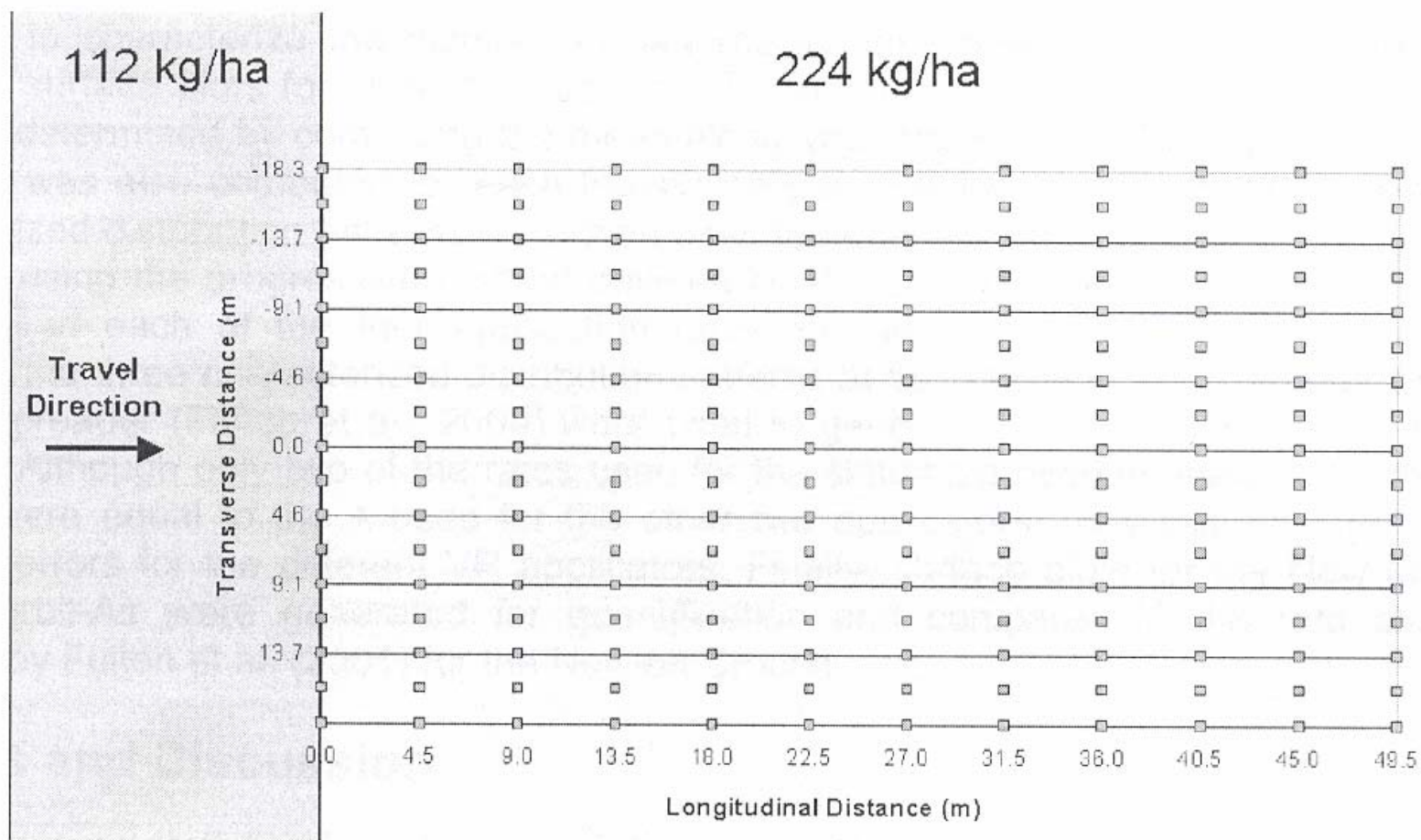

Figure 2. New Leader collection pan matrix for single-pass tests.

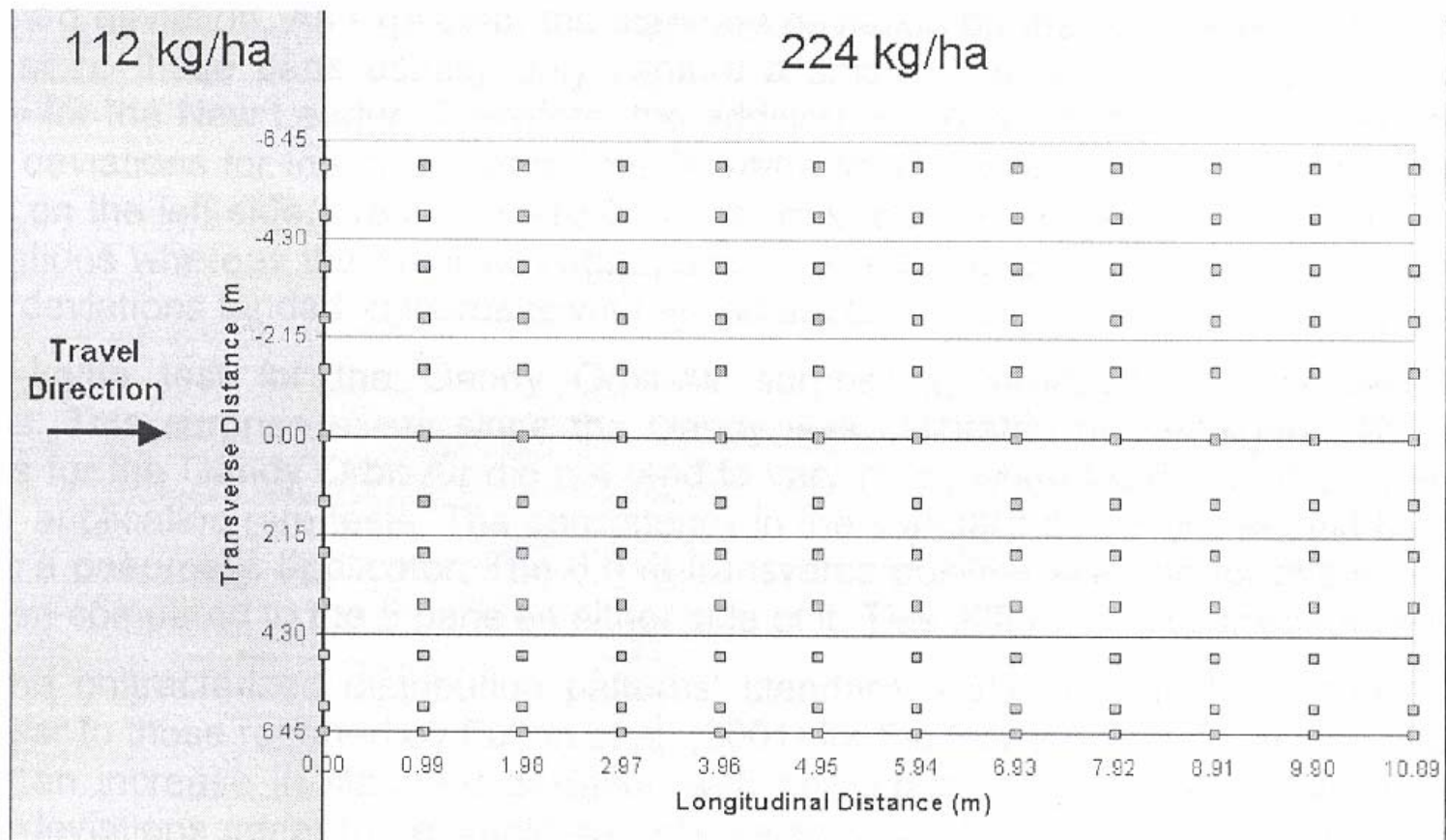

Figure 3. Gandy Orbit-Air collection pan matrix for single-pass tests.

Table 3. Single-pass summary statistics for New Leader.

Transverse Position (m)	56 kg/ha		112 kg/ha		224 kg/ha		336 kg/ha	
	AVG (kg/ha)	Std Dev	AVG (kg/ha)	Std Dev	AVG (kg/ha)	Std Dev	AVG (kg/ha)	Std Dev
-18.3	0.0	0.0	0.2	0.4	0.3	0.6	0.1	0.3
-16.0	0.0	0.0	2.1	4.1	0.7	1.3	2.1	2.7
-13.7	6.4	4.7	6.0	6.0	9.1	6.4	25.4	8.3
-11.4	17.5	6.3	29.95	10.6	52.2	21.1	121.7	20.7
-9.1	31.4	10.0	60.1	8.7	131.9	18.0	214.1	27.3
-6.9	33.4	5.7	75.8	16.8	150.2	17.6	217.2	29.8
-4.6	40.7	11.9	90.1	17.4	176.6	25.3	254.9	24.7
-2.3	51.0	13.4	114.6	24.1	193.4	29.7	267.0	20.5
0	52.0	11.7	100.9	21.0	226.1	24.1	327.7	25.8
2.3	44.7	12.8	94.3	22.2	181.0	16.7	254.5	22.4
4.6	38.9	5.8	79.6	15.8	167.1	15.4	247.5	30.0
6.9	30.1	7.2	59.3	13.7	142.1	17.6	199.5	17.0
9.1	30.4	8.5	55.7	8.9	114.8	19.2	174.8	17.5
11.4	25.8	9.0	41.2	4.9	88.0	13.8	118.4	23.5
13.7	15.4	7.7	21.2	9.9	40.4	13.1	43.4	9.1
16.0	7.3	4.0	5.9	7.0	6.2	4.2	9.5	5.8
18.3	0.9	2.1	2.0	3.5	2.0	3.9	0.9	1.5

on patterns show consistency from side to side

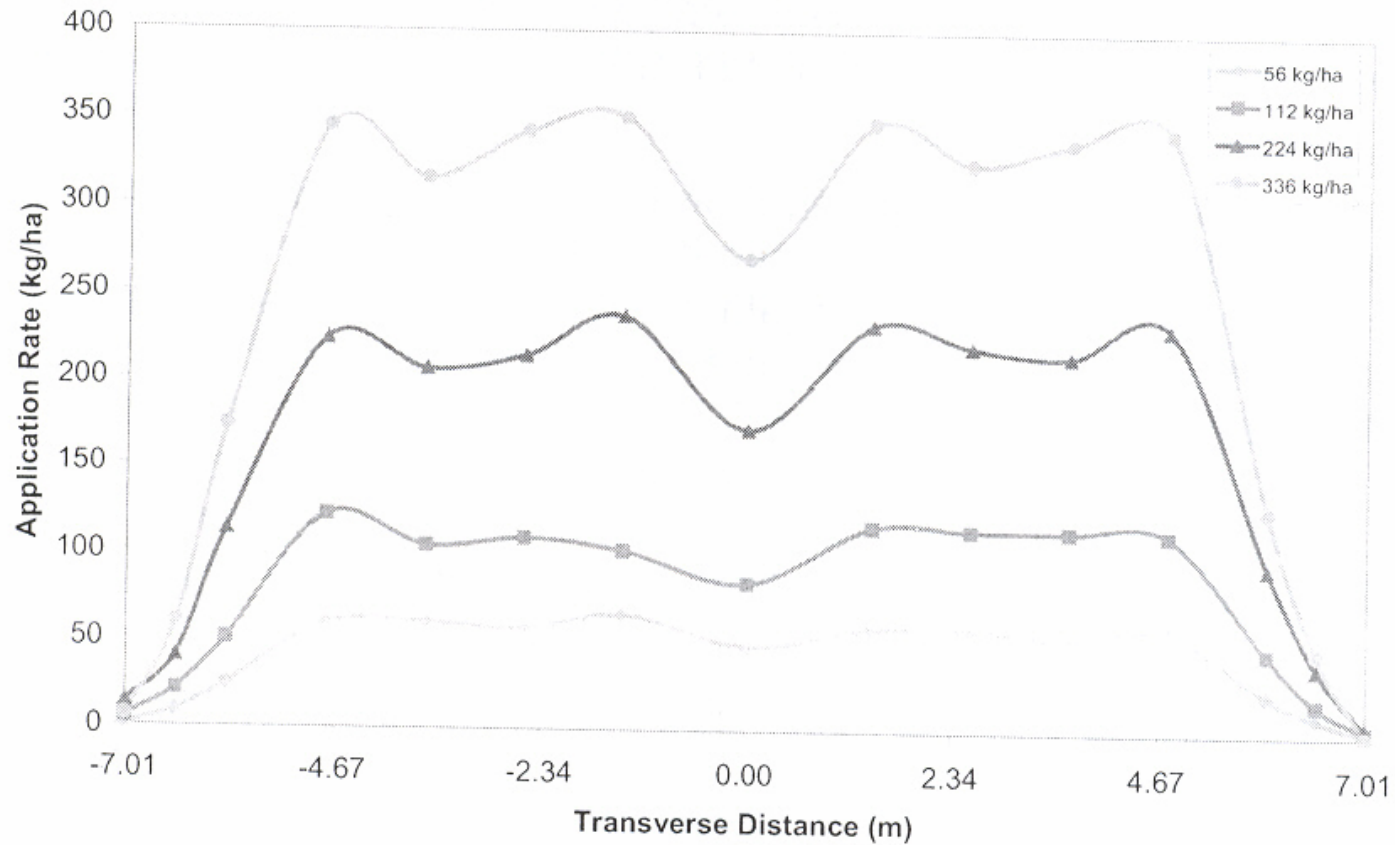

Figure 4. Characterized distribution patterns for the Gandy Orbit-Air.



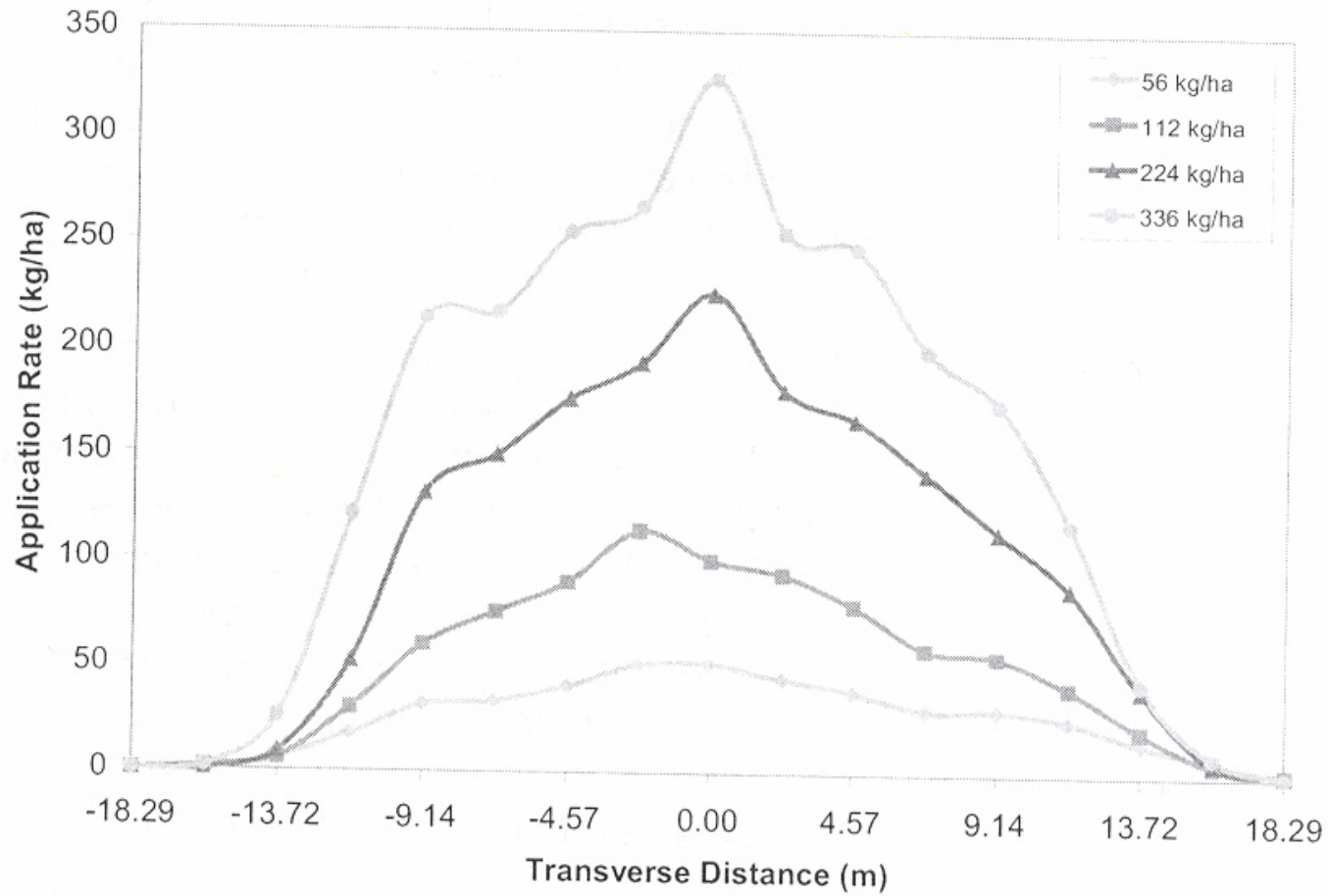

Figure 5. Characterized distribution patterns for the New Leader.

m exists for the Candy Orbit Air.

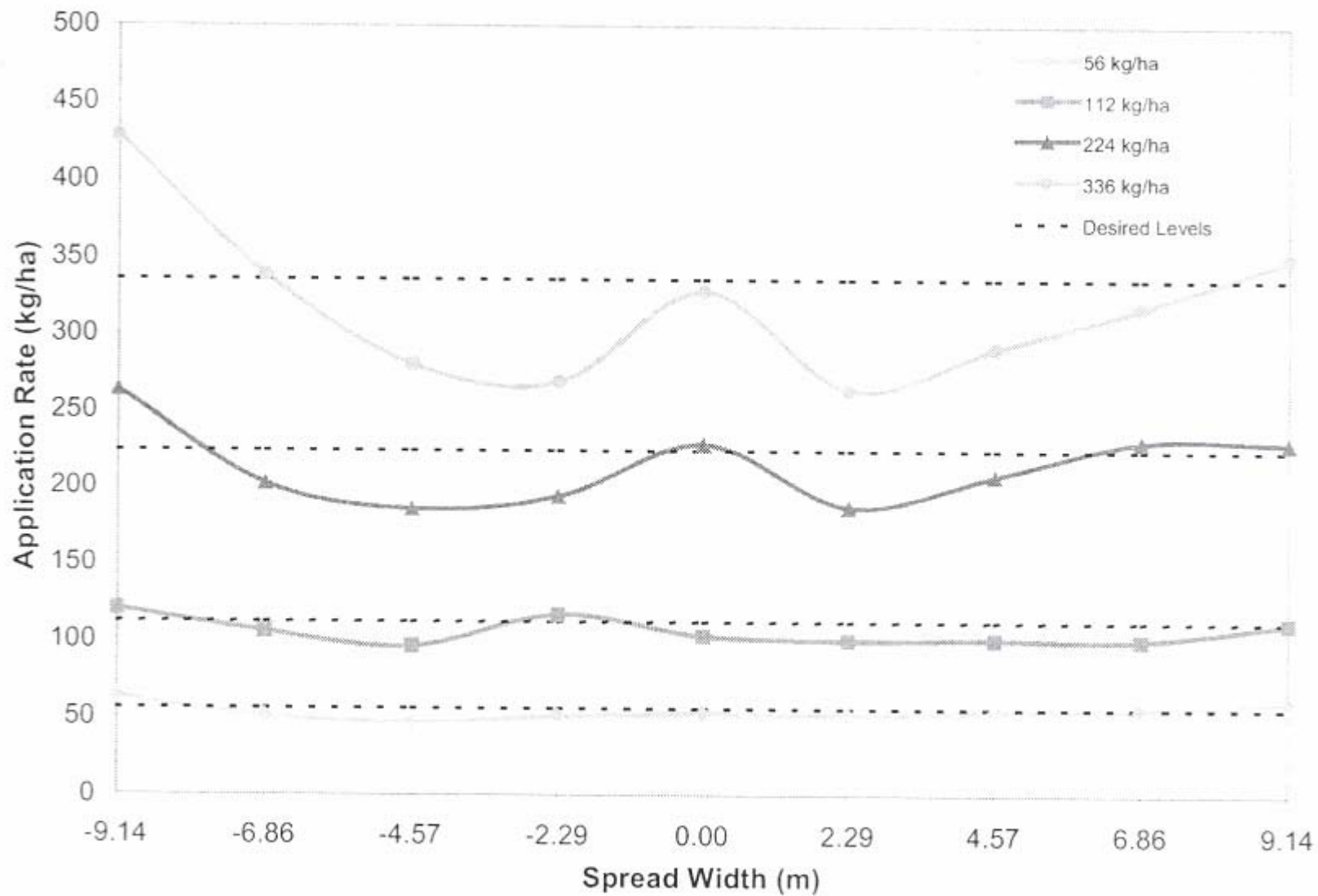

Figure 6. Simulated overlap distribution pattern for New Leader.

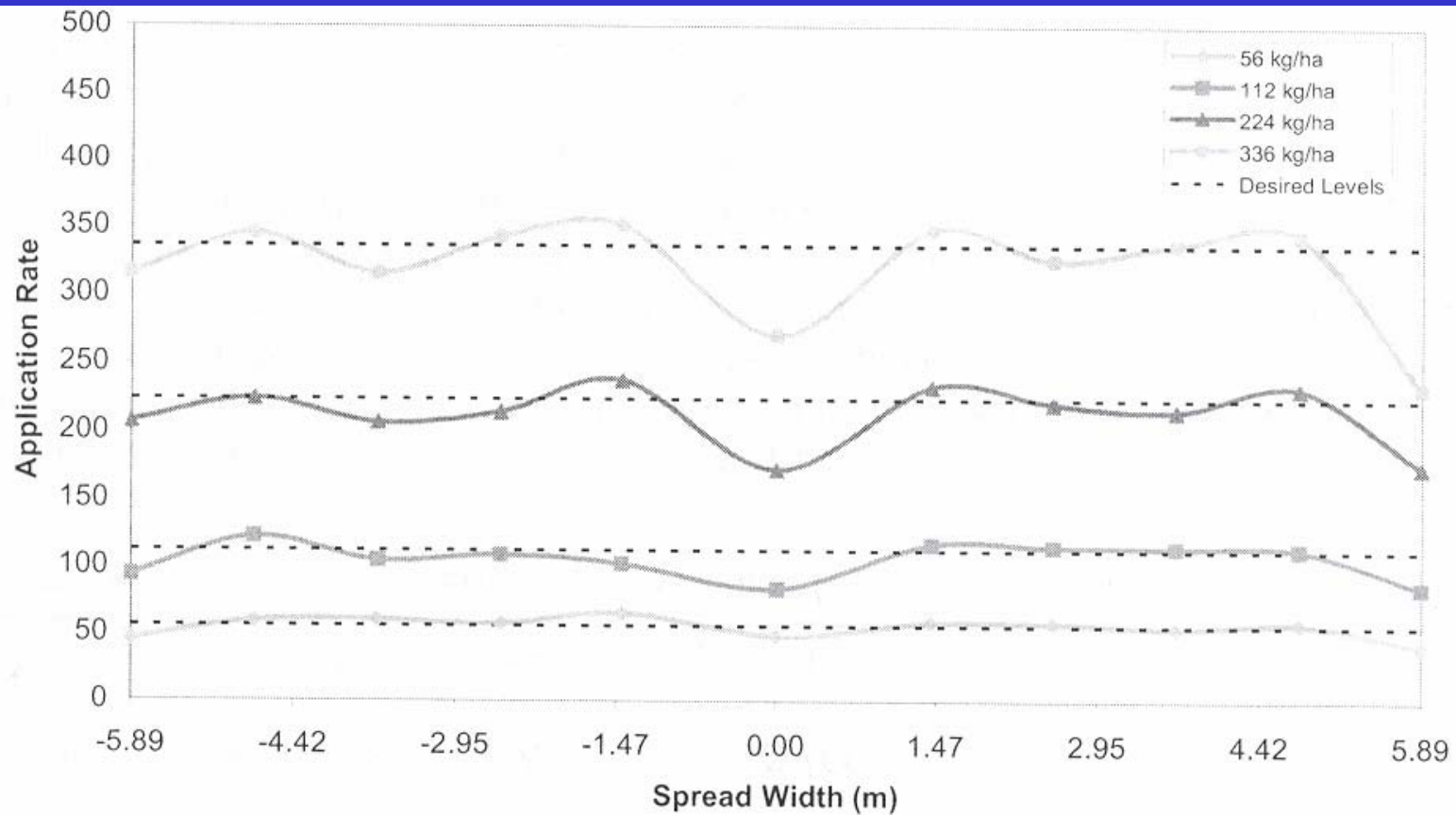

Figure 7. Simulated overlap distribution pattern for the Gandy Orbit-Air.

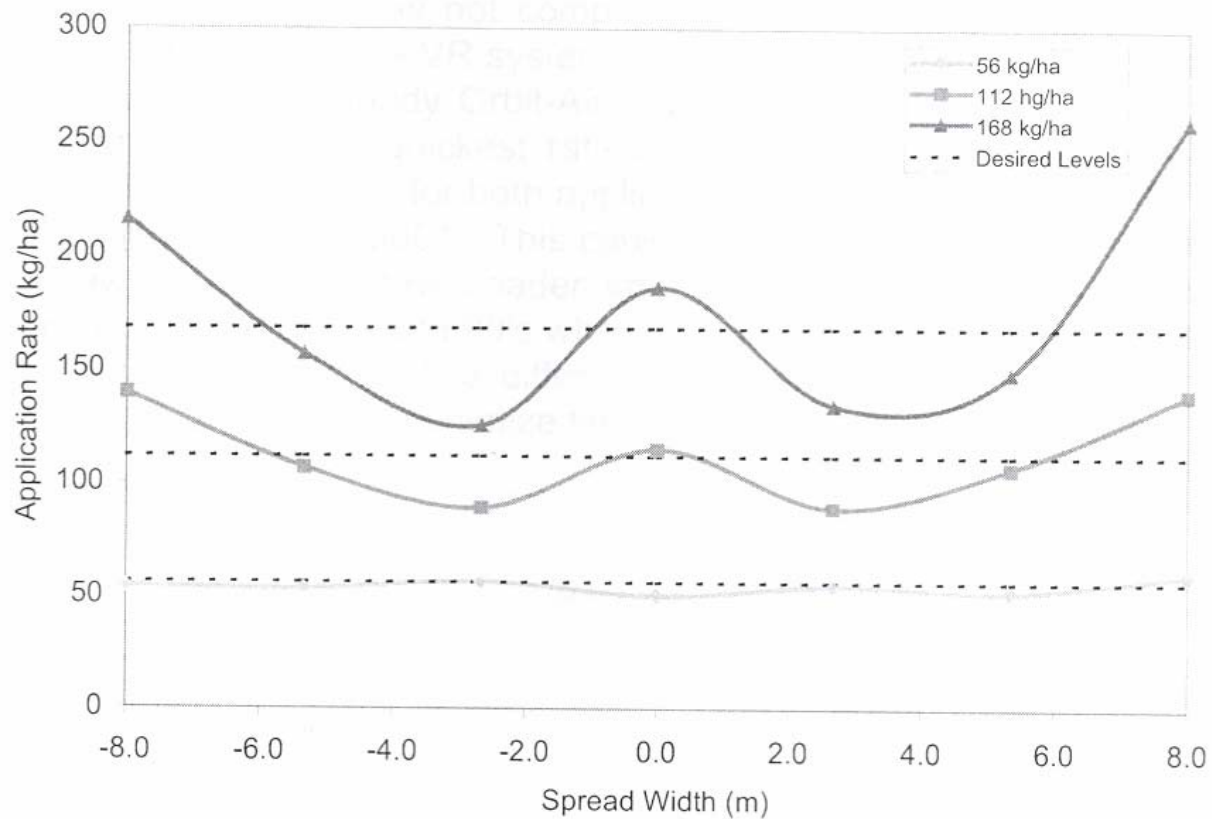

Figure 8. Simulated overlap distribution pattern for Newton Crouch.

Table 4 presents the overlap data statistical summary. The overall average and CV are reported. The CV's are all within an acceptable range (< 20%) except for the 168-kg/ha test from the Newton Crouch. A high percentage of the CV's are below 15%. These CV's specify an acceptable spread by these applicators. The overlap plots (figs. 6, 7, and 8) tended to show more variation than the CV's meaning that the CV's can be used to quantify distribution variability but overlap plots are needed to make good conclusions about the quality of

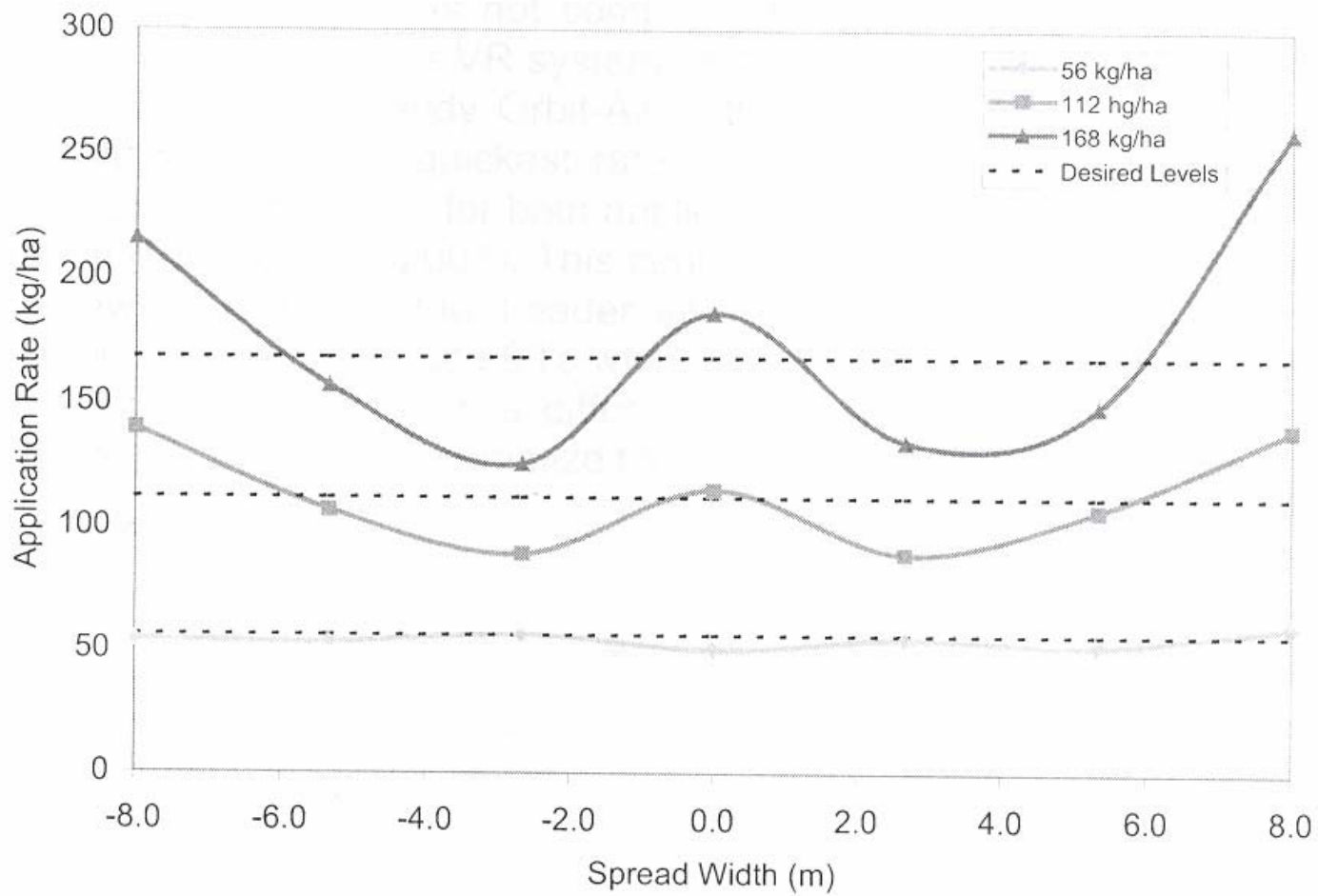

Figure 8. Simulated overlap distribution pattern for Newton Crouch.

Table 4. Simulated multiple pass summary statistics (progressive method).

Desired Rate	Gandy Orbit-Air		New Leader		Newton Crouch	
	AVG (kg/ha)	CV (%)	AVG (kg/ha)	CV (%)	AVG (kg/ha)	CV (%)
56 kg/ha	55.2	13	54.2	9.2	54.2	5.8
112 kg/ha	105.4	12.3	106.1	7.8	112.3	18.6
168 kg/ha	-	-	-	-	175.2	27.4
224 kg/ha	212.5	10.2	214.3	12	-	-
336 kg/ha	320.6	11.6	318.6	16.1	-	-

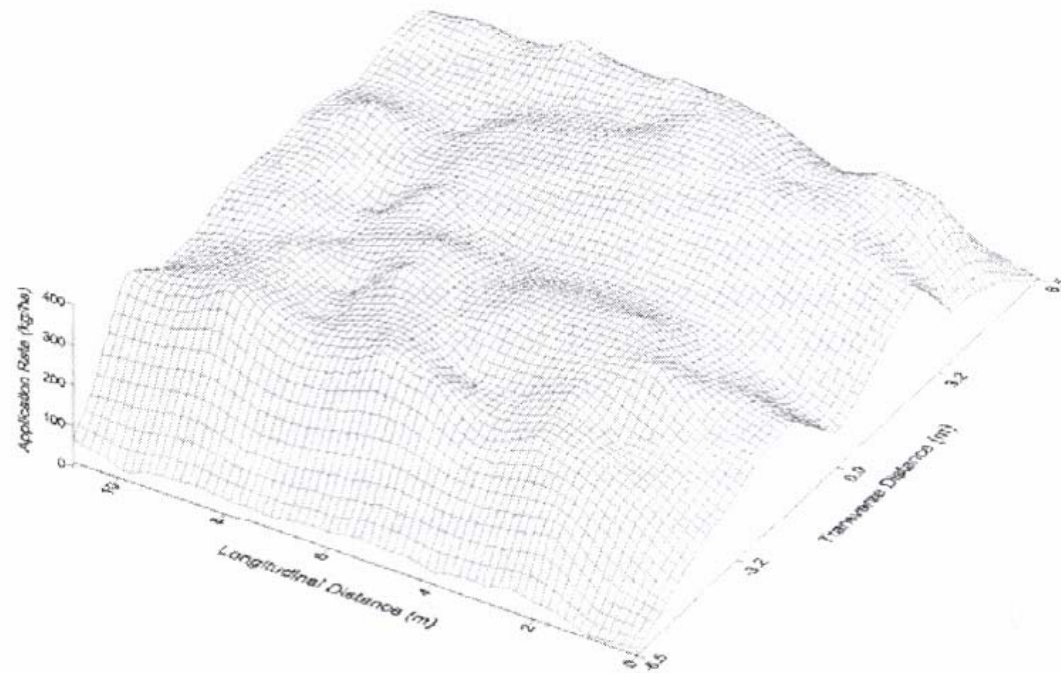

Figure 9. Rate change application surface for the Gandy Orbit-Air (rate change from 112 to 336 kg/ha).

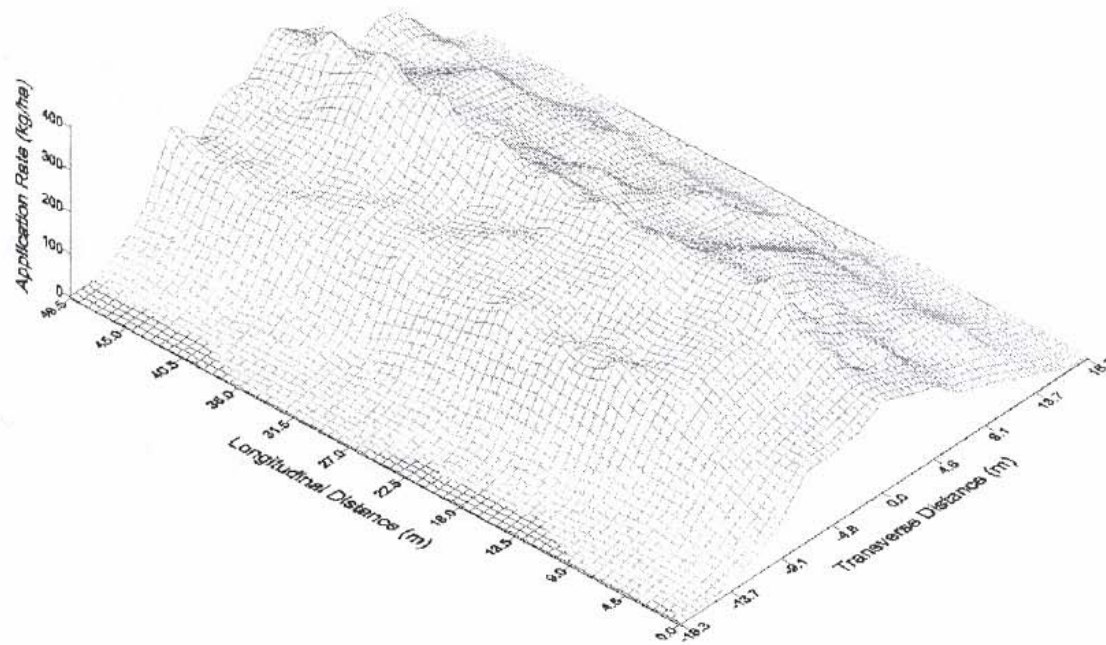
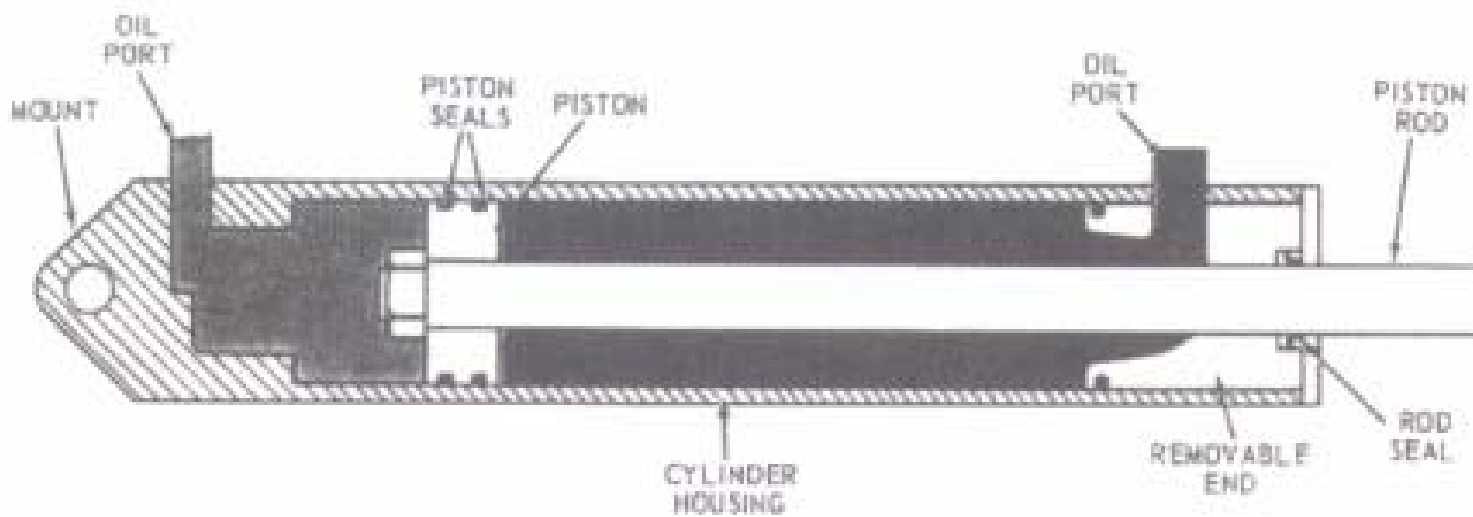
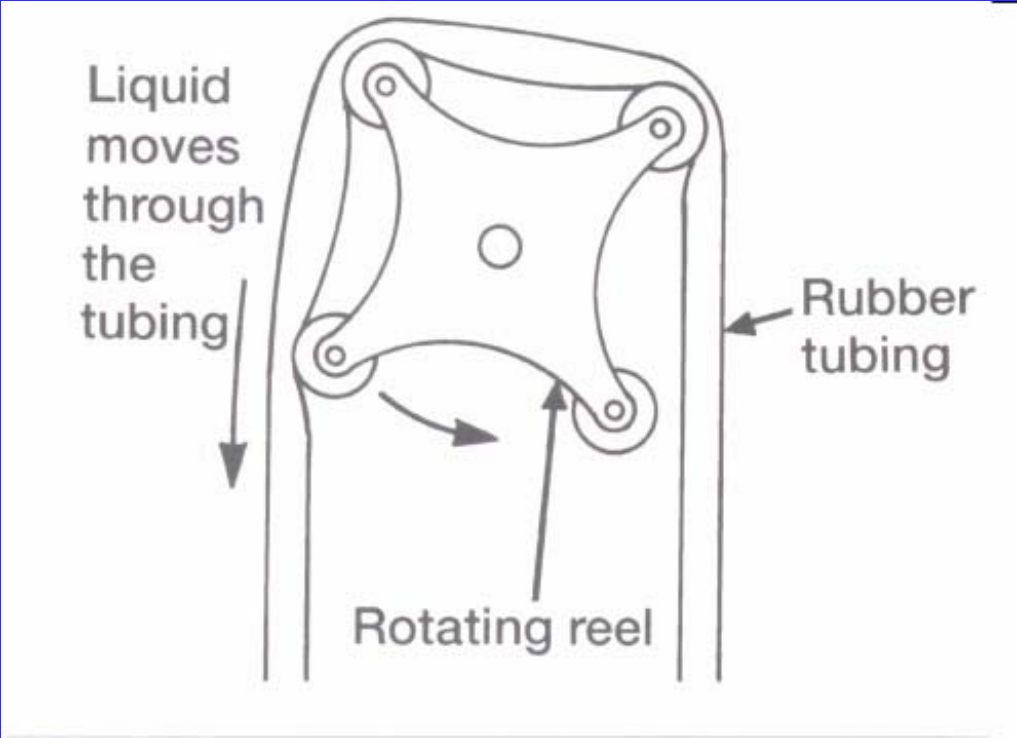
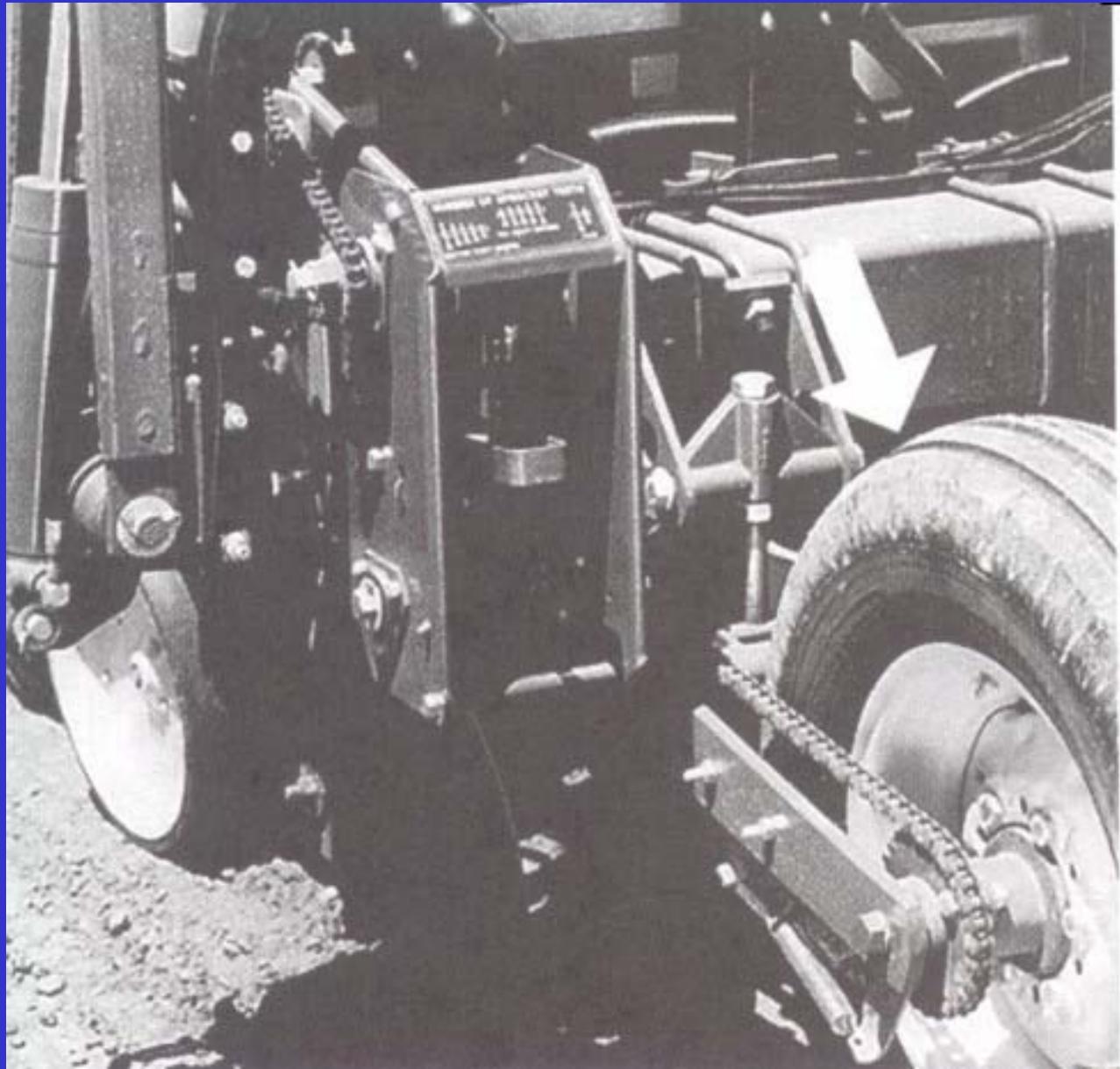

Figure 10. Rate change application surface for the New Leader (rate change from 112 to 336 kg/ha).









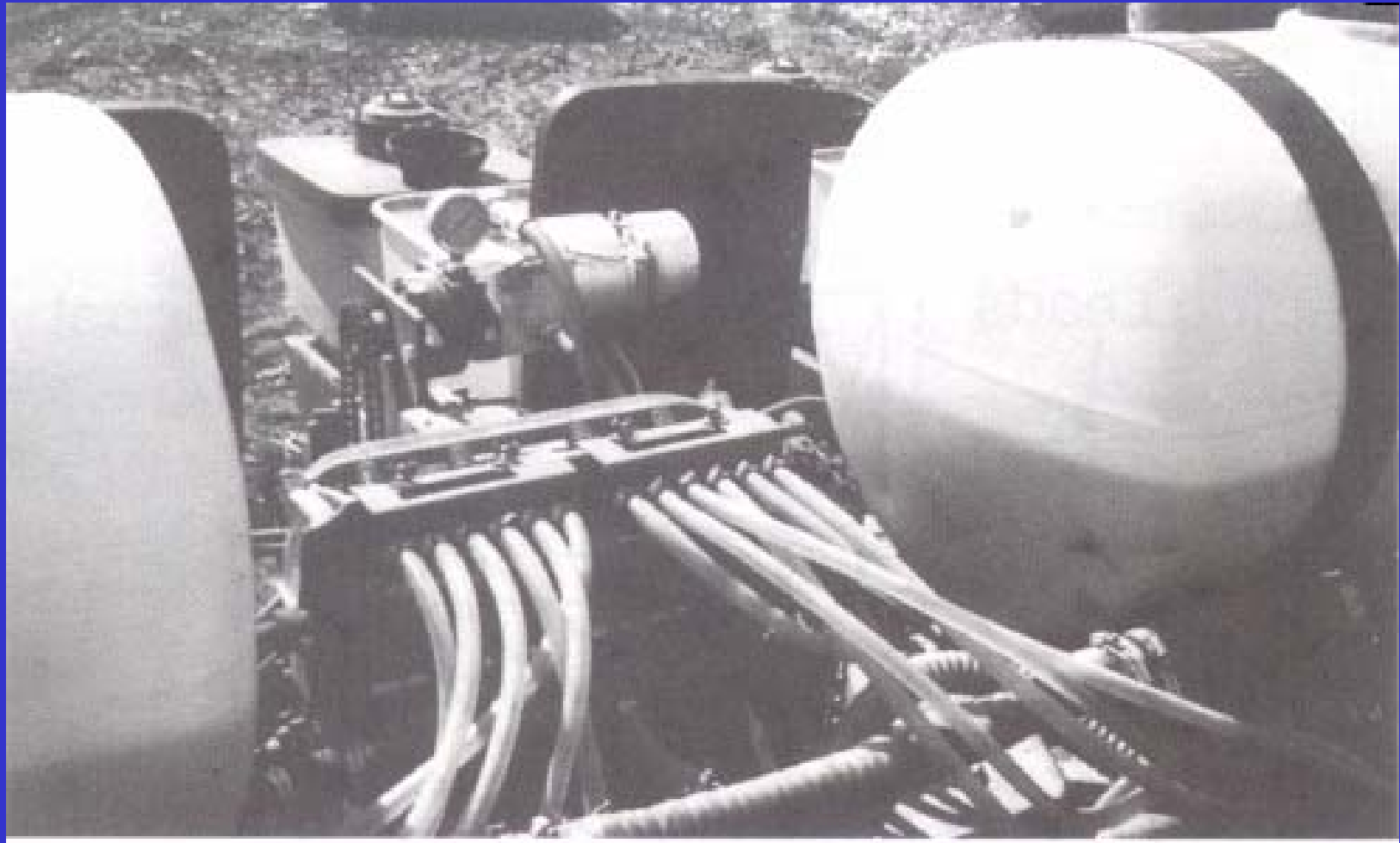

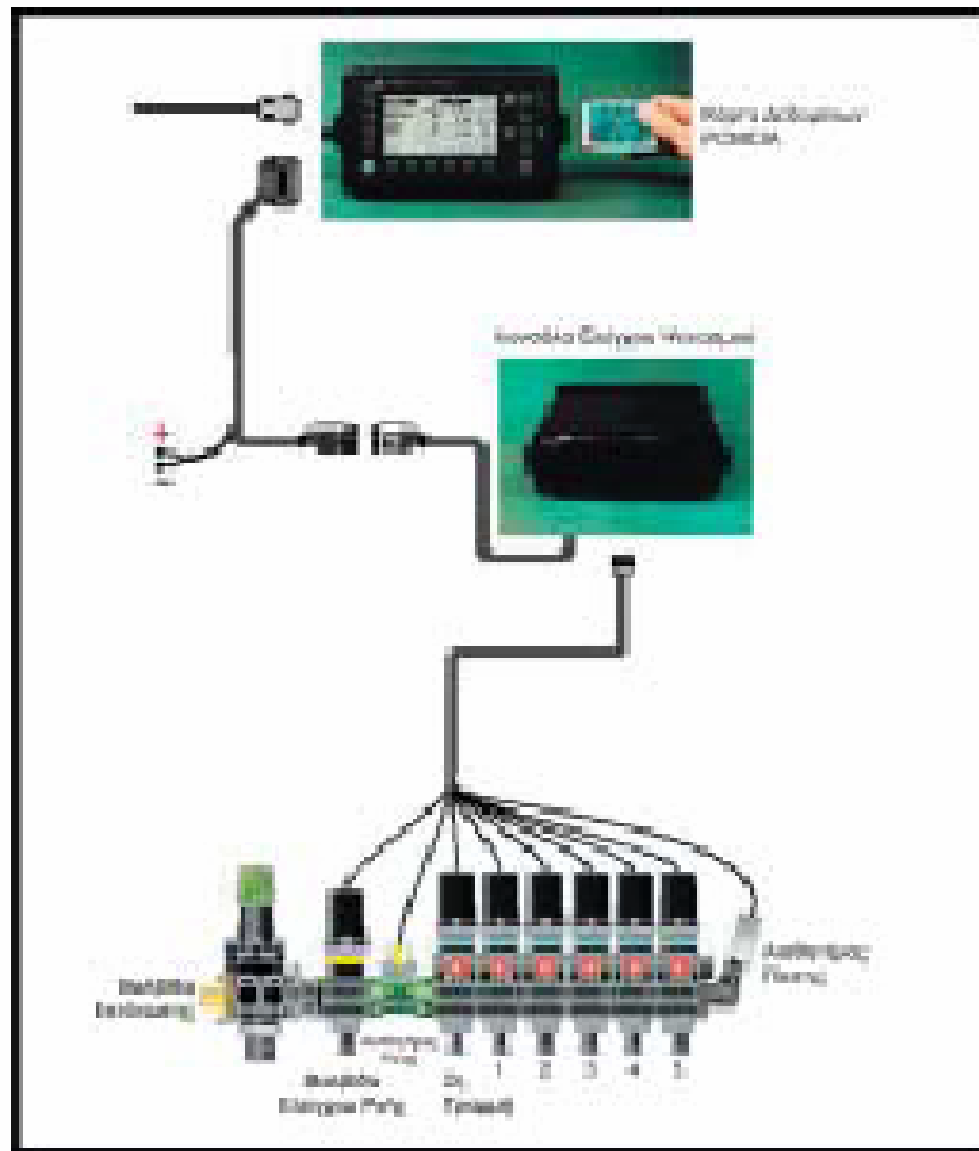

Εικ. 16. Εξοπλισμός Εφαρμογής Διαφοροποιούμενης Δόσης Υγρών, FamScan.







Sensori di semina,
controllo file, ecc.

Data di semina,
varietà, densità, ecc.

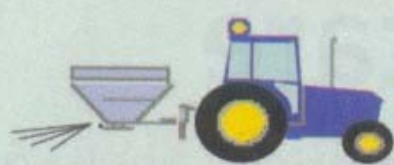

Controllo portata di efflusso,
impostazioni dischi distributori, ecc.

Date di concimazione, fertilizzanti
impiegati, dosi applicate, ecc.



Flussimetro, controllo
sezioni della barra, ecc.

Date dei trattamenti,
fitofarmaci impiegati,
dosi applicate, ecc.



Sensore di resa,
sensore di umidità, ecc.

Data di raccolta,
appezzamento, resa, ecc.

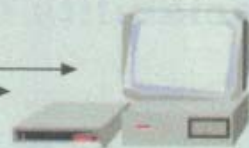

Quaderno di campagna
aziendale

«Etichetta virtuale» per ogni unità
di prodotto:
■ appezzamento di origine;
■ data di semina e di raccolta;
■ numero di trattamenti fertilizzanti
e fitoterapici, prodotti utilizzati,
data di applicazione, dosi;
■ altro



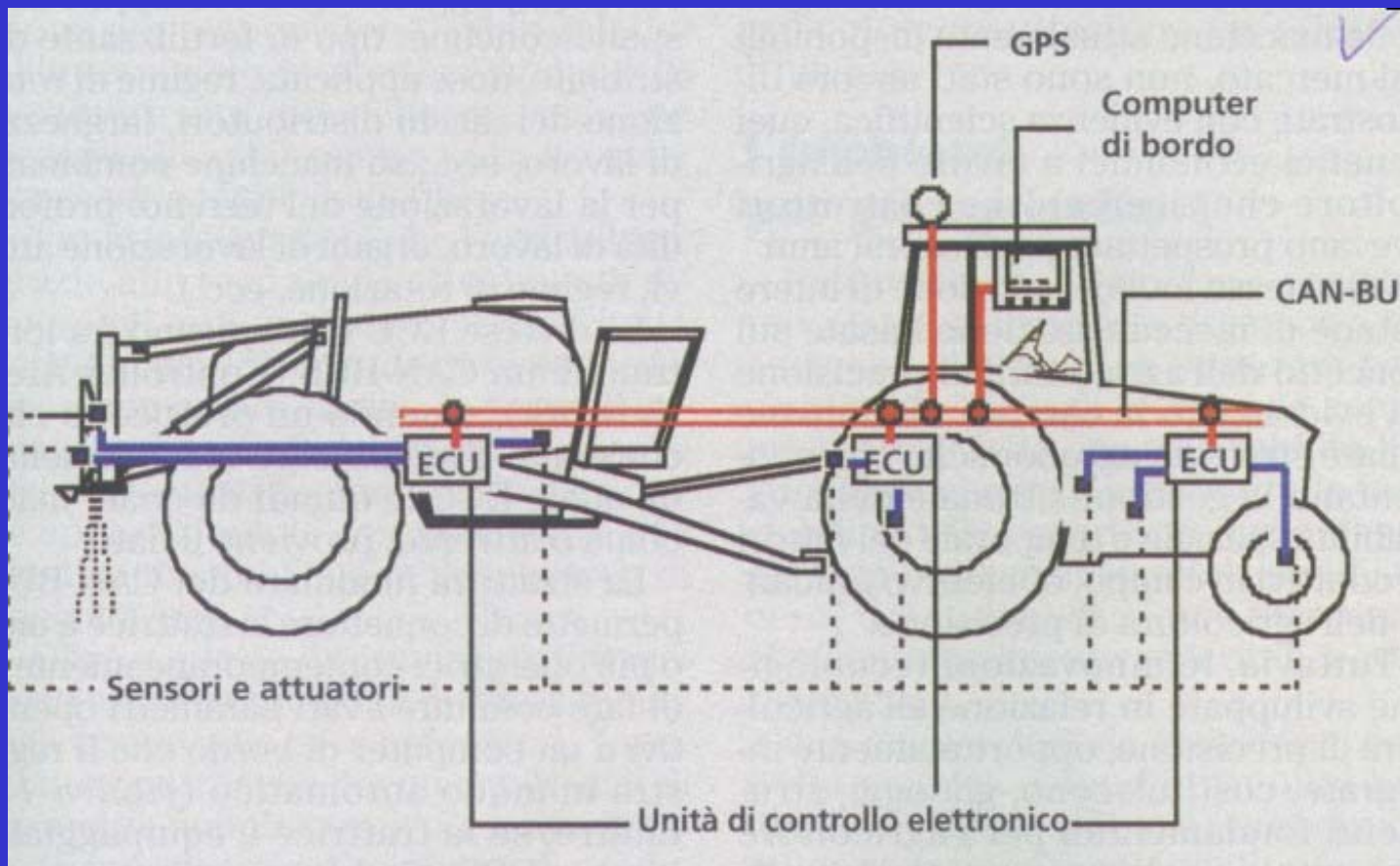



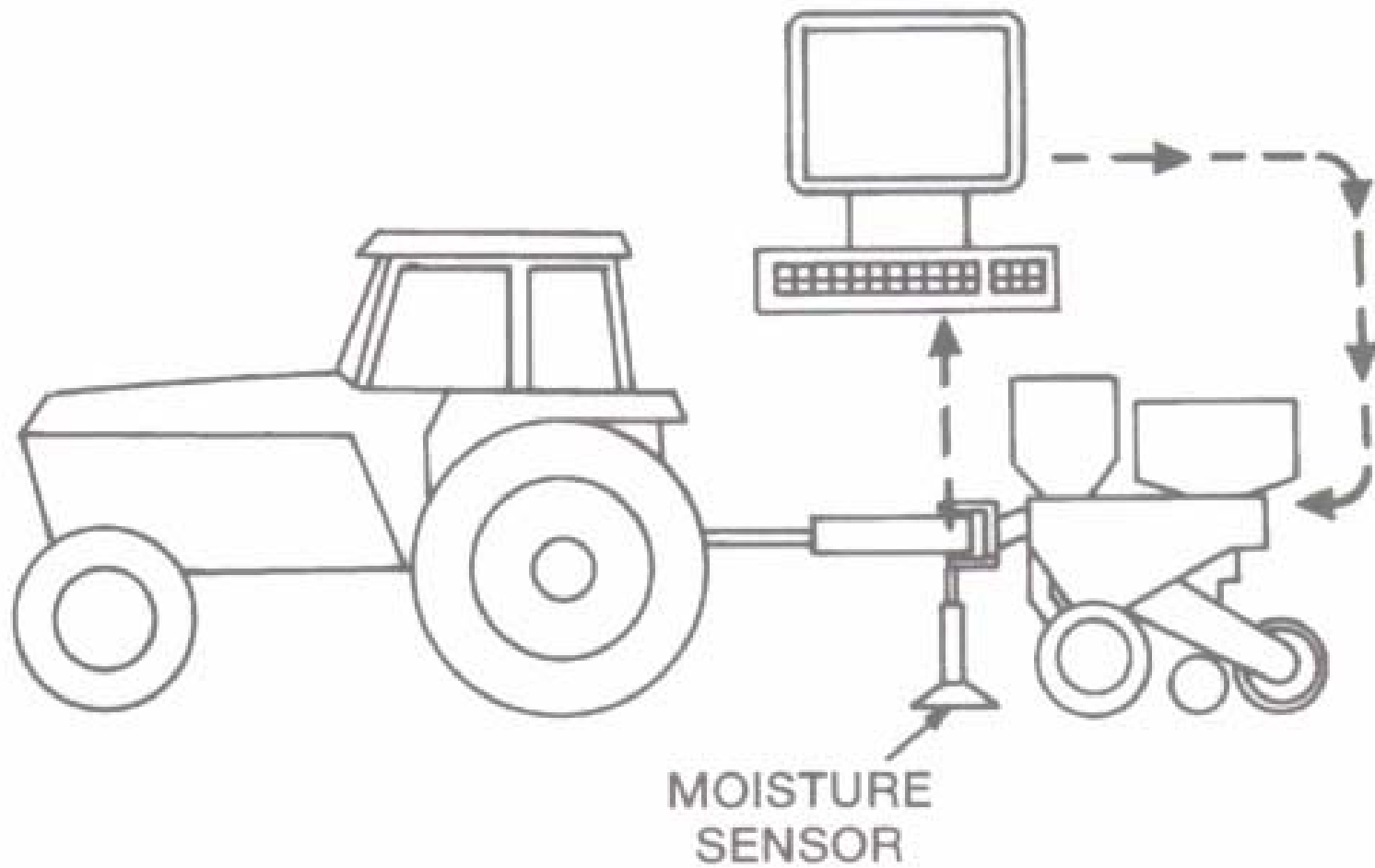

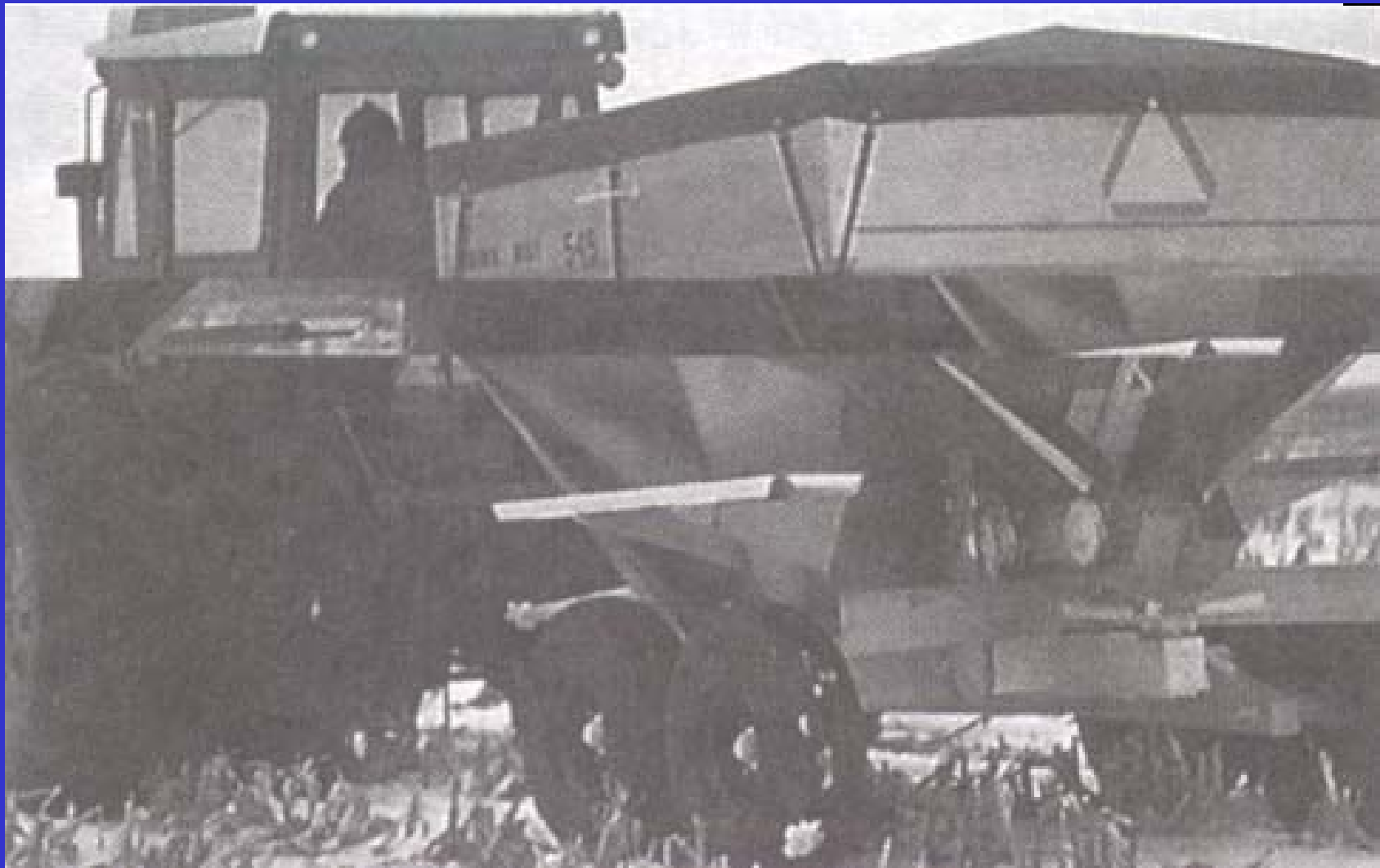





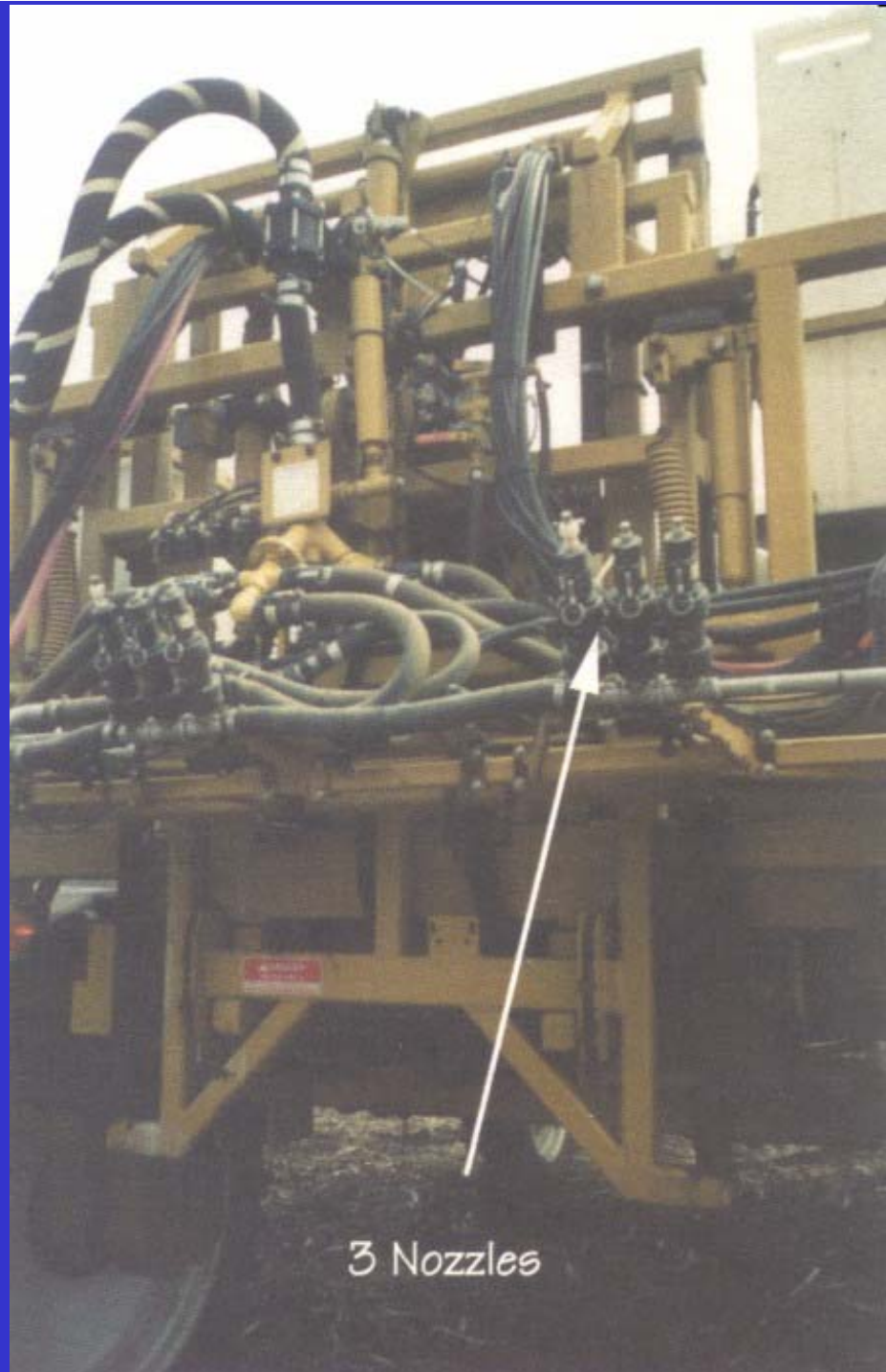

3 Nozzles

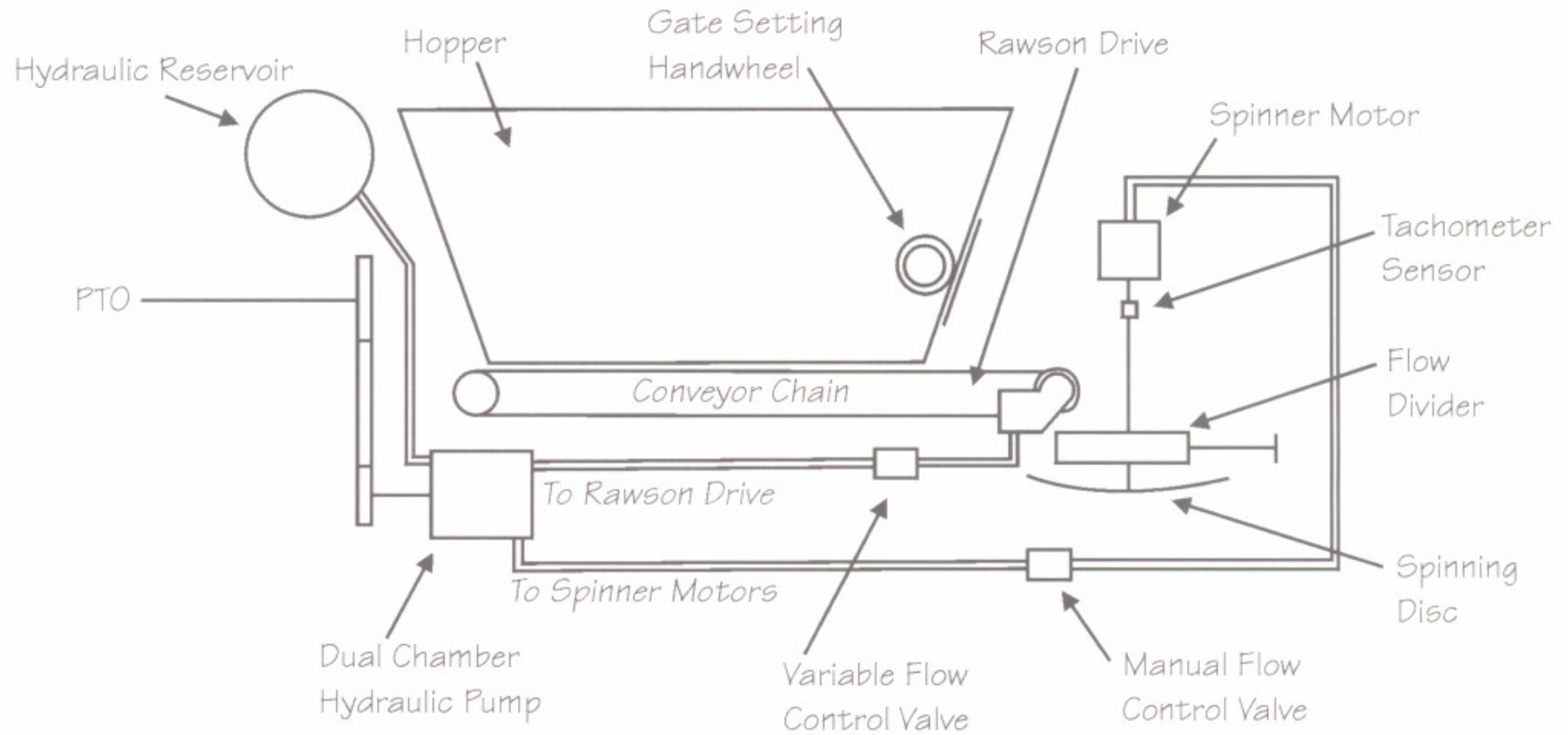

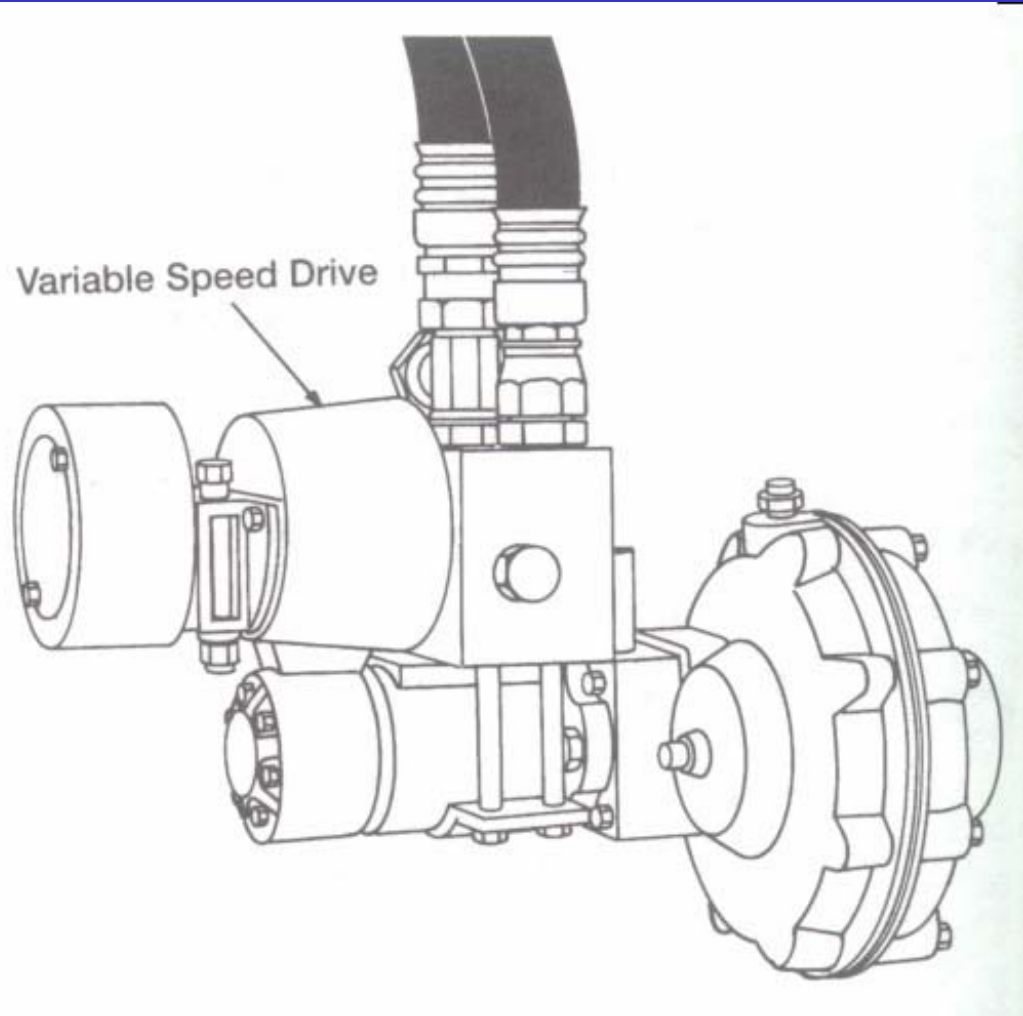

Variable Speed Drive







Soil Texture	Broadcast Rates Per Acre			
	Less Than 3% Organic Matter		3% Organic Matter or Greater	
	Tank Mix 1	or Tank Mix 2	Tank Mix 1	or Tank Mix 2
COARSE	1.25-1.5 pts. + 1.1-2.2 lbs.	1.25-1.5 pts. + 0.6-1.1 lbs. + 0.6-1.1 lbs.	1.5 pts. + 1.3-2.2 lbs.	1.5 pts. + 0.7-1.1 lbs. + 0.7-1.1 lbs.
MEDIUM	1.5-2 pts. + 1.3-2.2 lbs.	1.5-2 pts. + 0.7-1.1 lbs. + 0.7-1.1 lbs.	2 pts. + 1.8-2.2 lbs.	2 pts. + 0.9-1.1 lbs. + 0.9-1.1 lbs.
FINE	2 pts. + 1.8-2.2 lbs.	2 pts. + 0.9-1.1 lbs. + 0.9-1.1 lbs.	2-2.5 pts. + 1.8-2.2 lbs.***	2-2.5 pts. + 0.9-1.1 lbs.*** + 0.9-1.1 lbs.***
Muck or Peat (soils with more than 20% organic matter)	DO NOT USE			

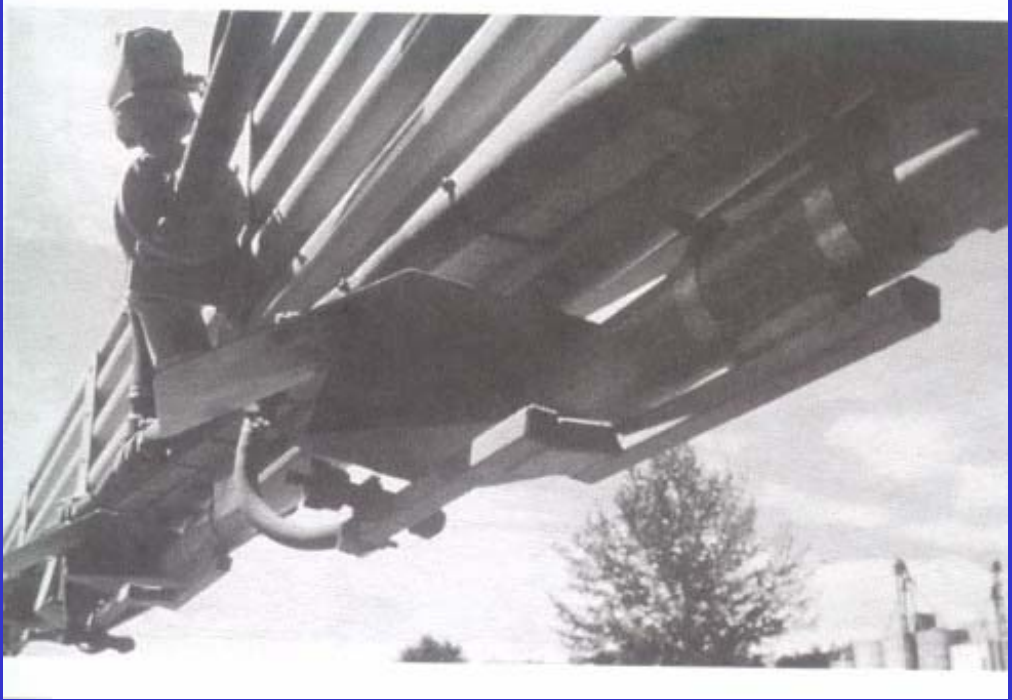

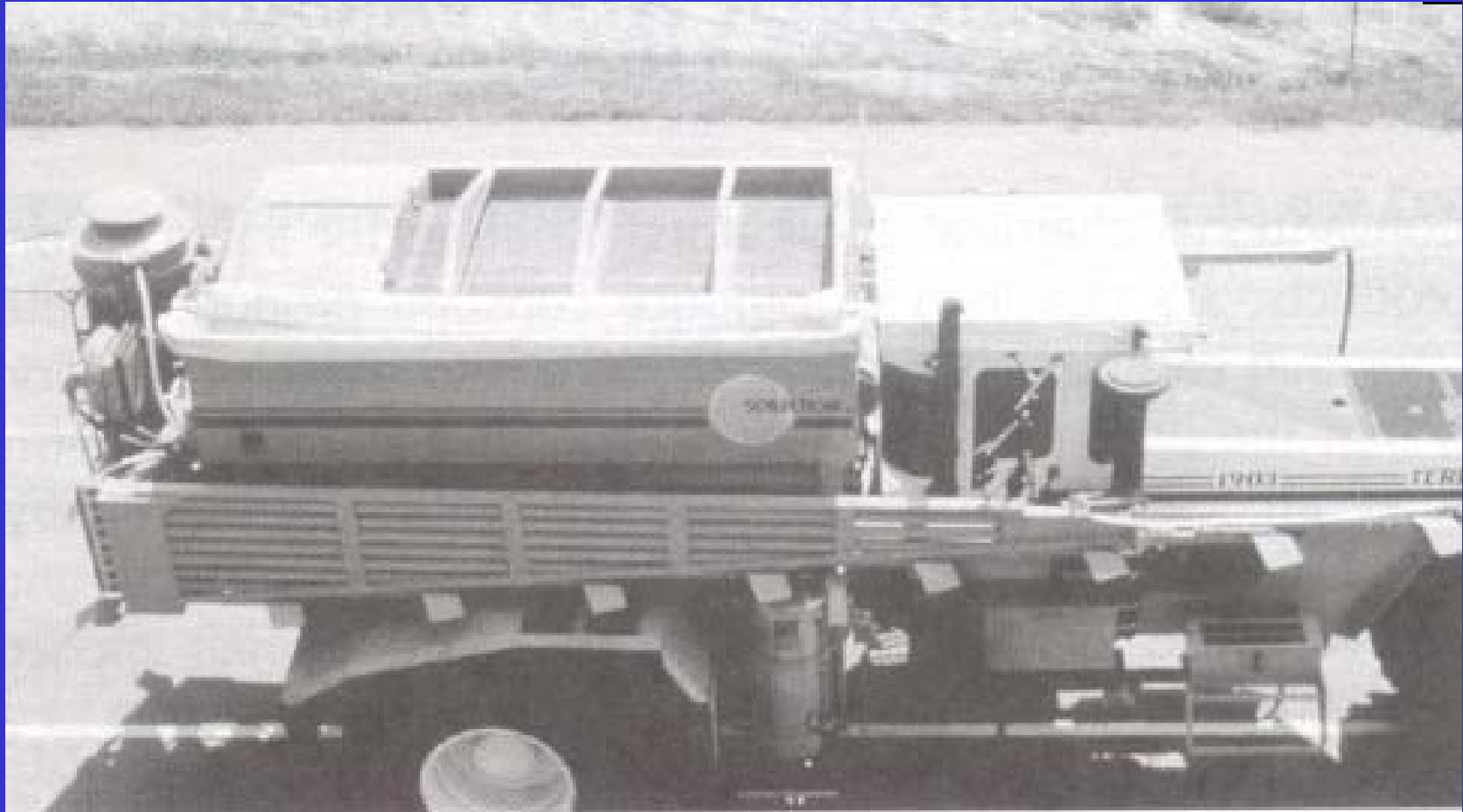

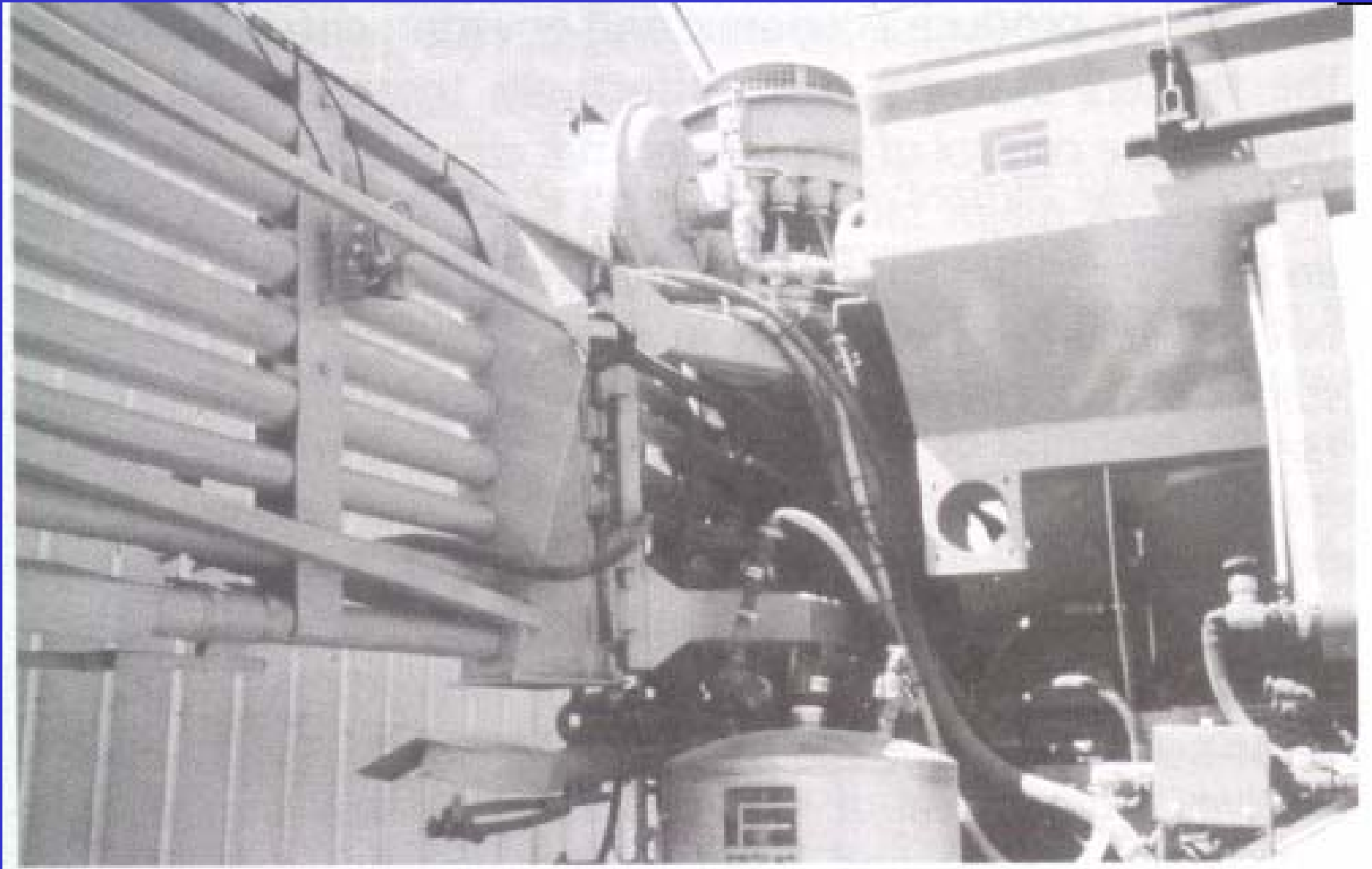

@ 10 psi

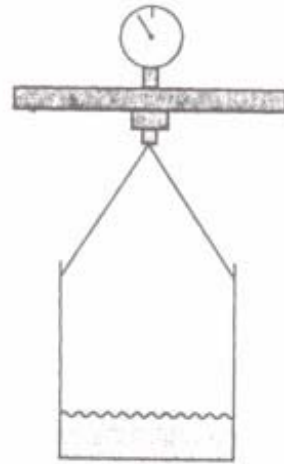

.1 GPM

@ 40 psi

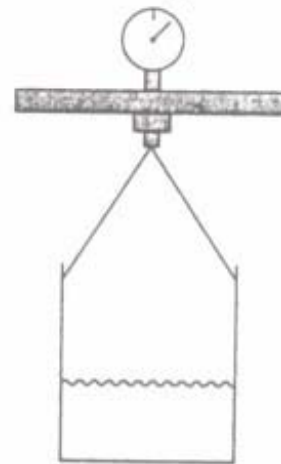

.2 GPM

@ 15 psi

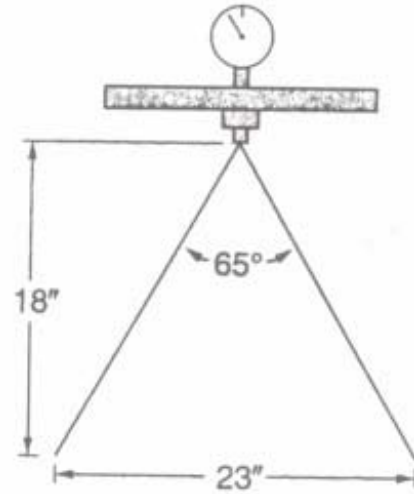

@ 40 psi

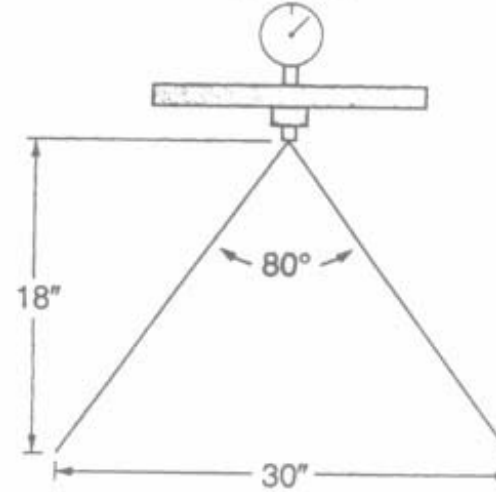



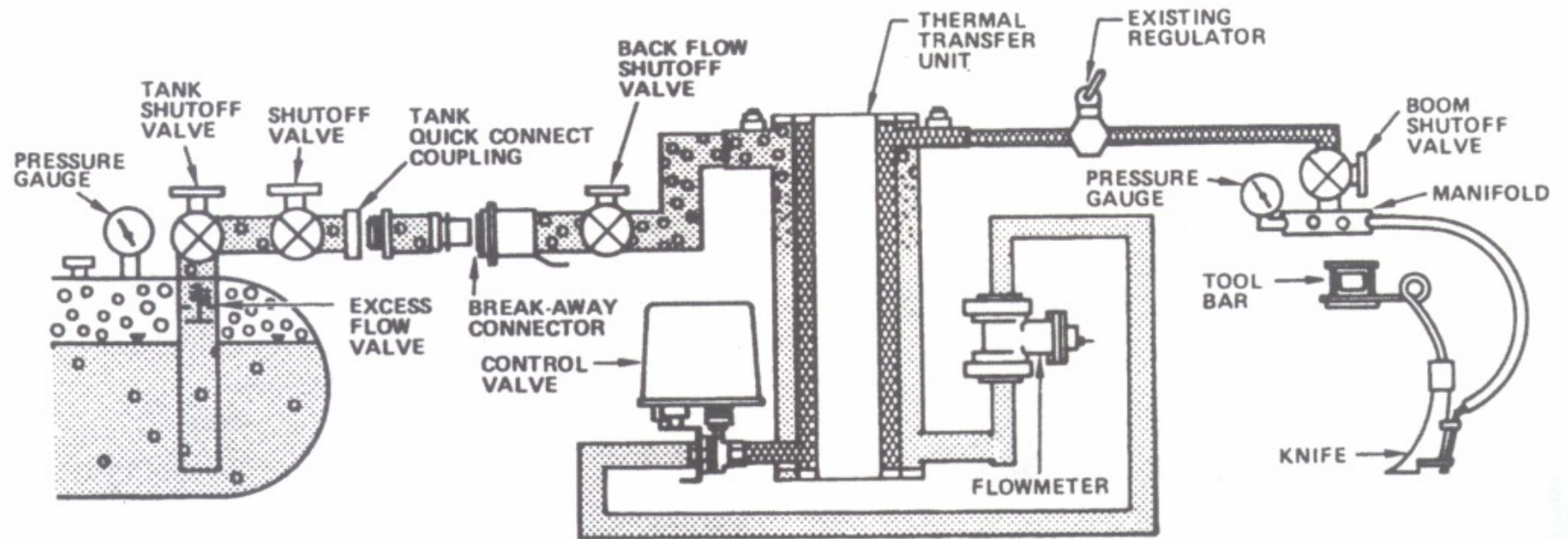



Mixing Manifold





Επιλεκτικός ψεκασμός ζιζανίων

WeedSeeker[®]

ΣΥΣΤΗΜΑ ΕΠΙΛΕΚΤΙΚΟΥ ΨΕΚΑΣΜΟΥ

**ψεκάστε έξυπνα
αυξήστε τα κέρδη σας**



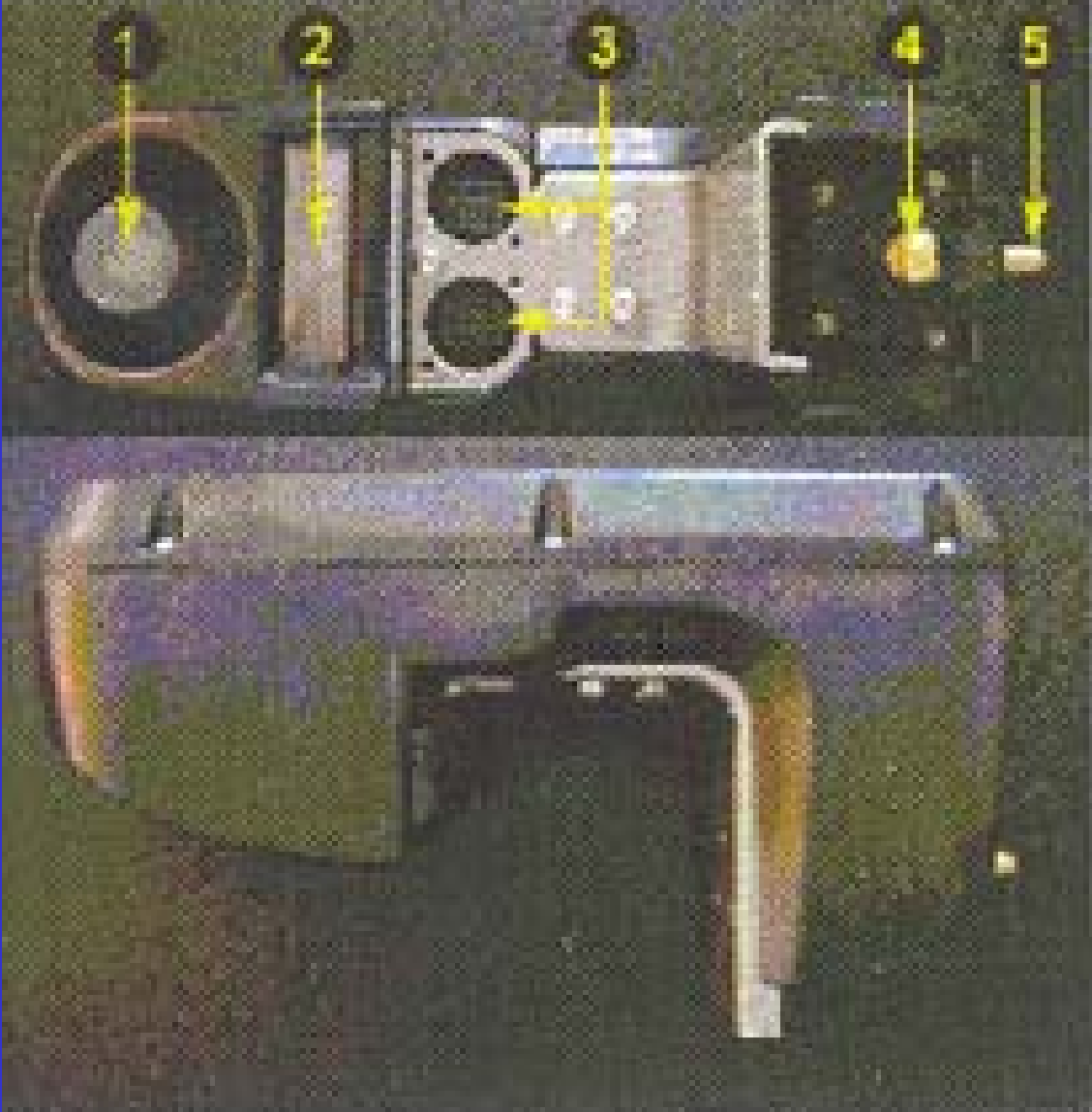

1
2
3
4
5

Πορεία Μηχανήματος

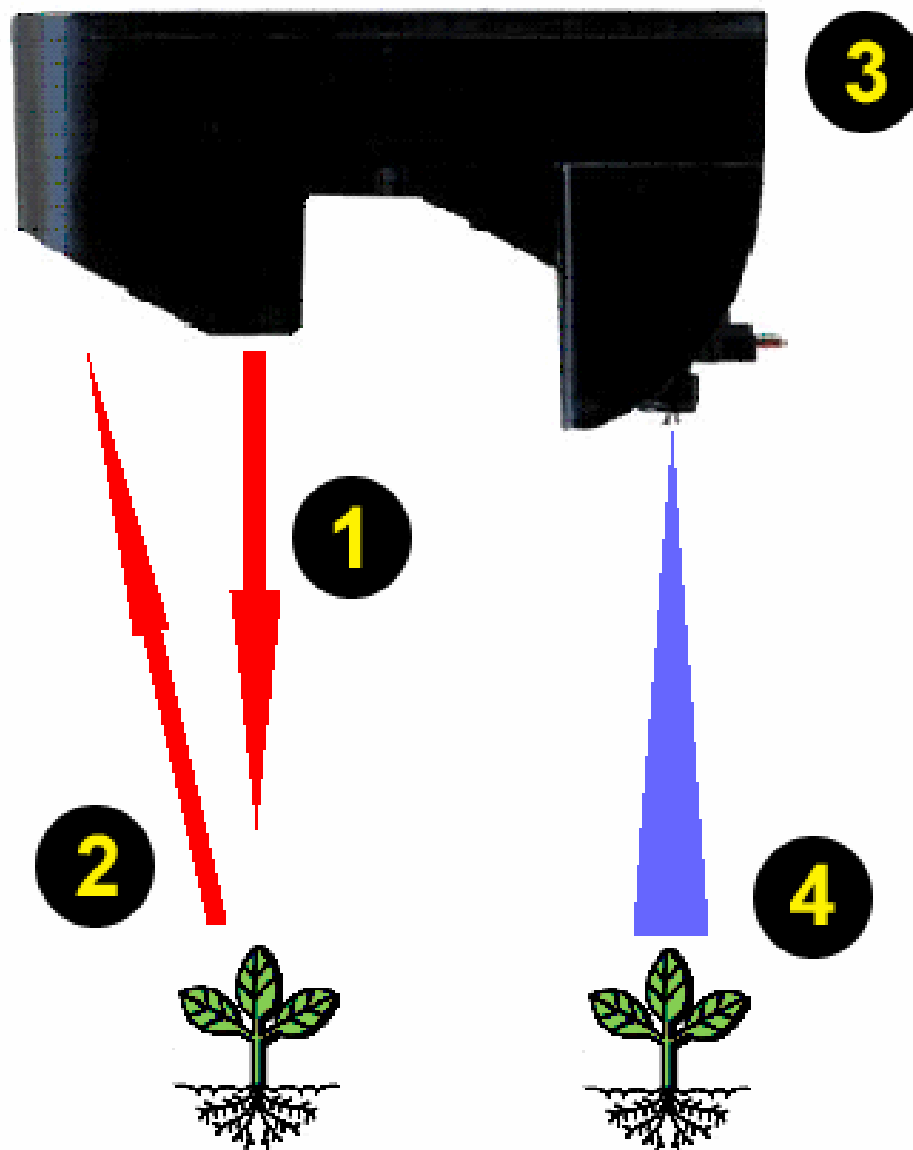







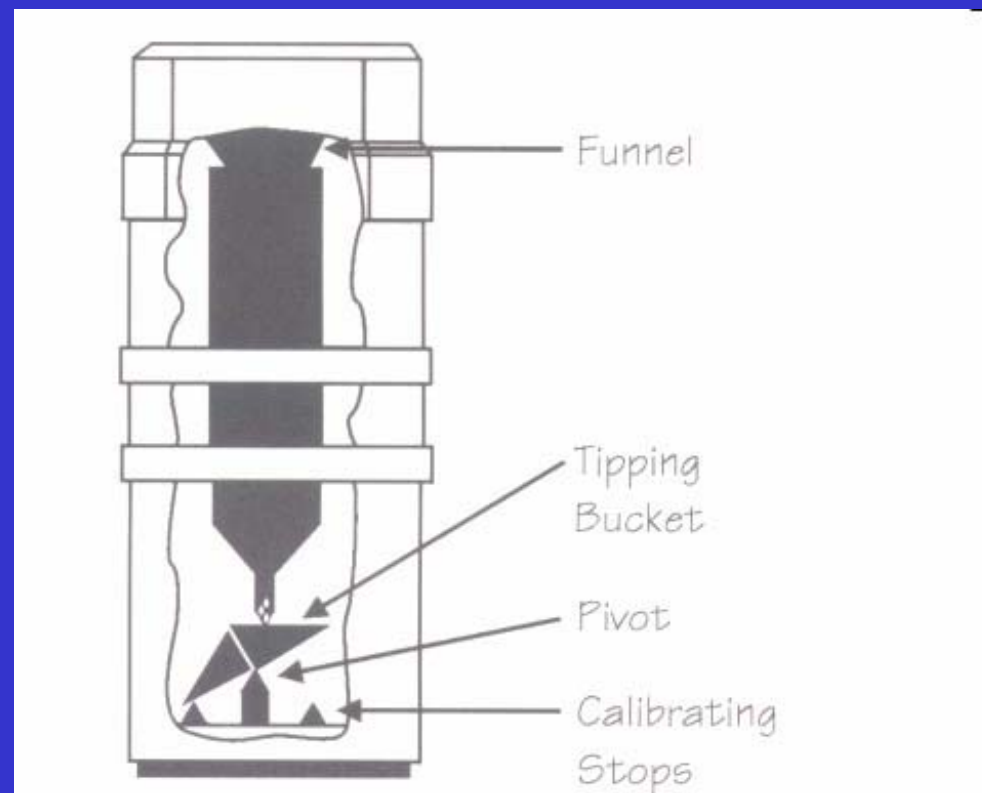











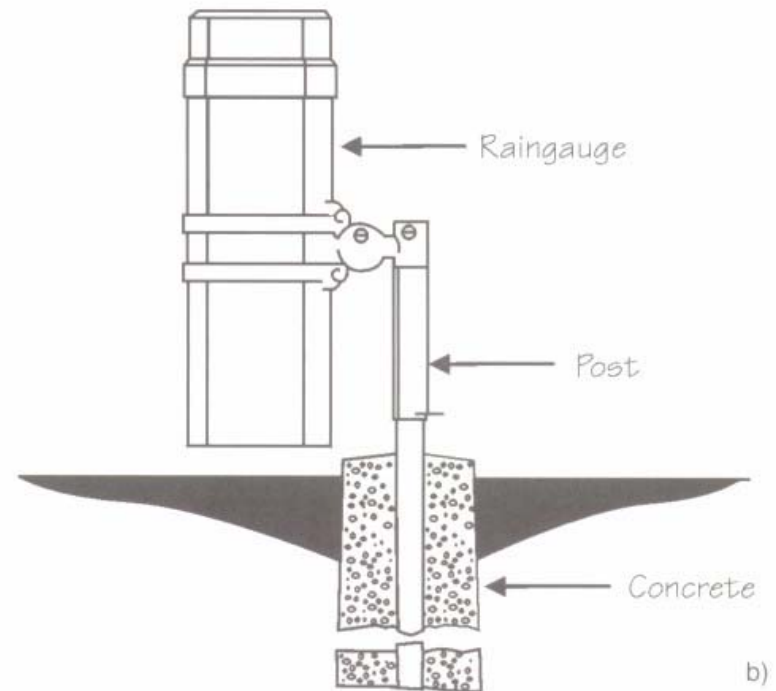
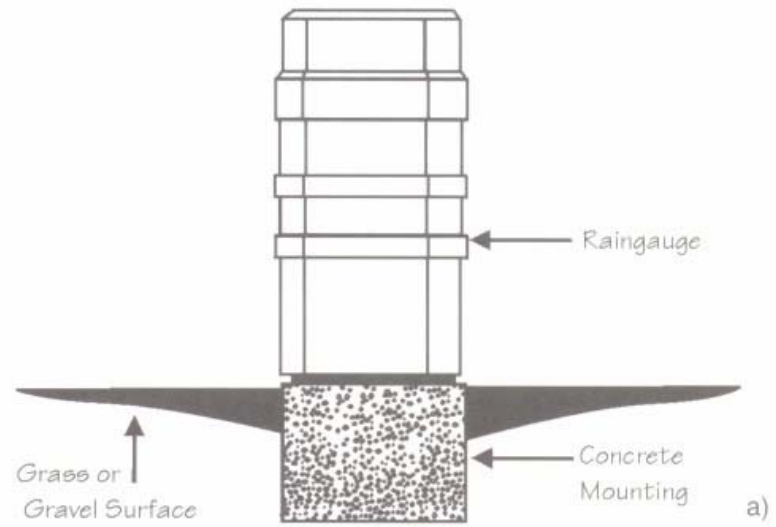
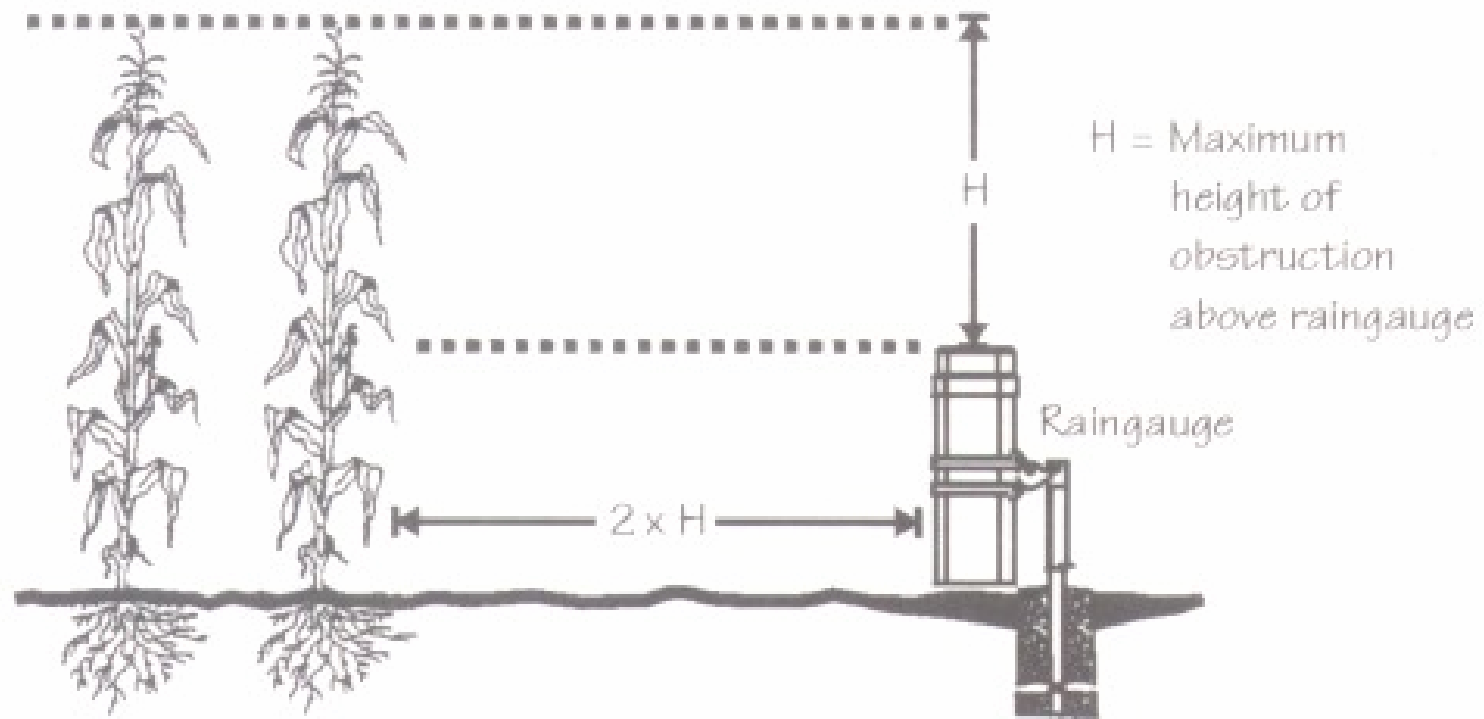

Figure 4





a

PUMIS Sensor

150 watt bulbs provides
consistent lighting in
daytime and offer
potential for nighttime
spraying



Μετατρέποντας τα Γεωγραφικά Δεδομένα σε Πληροφορία

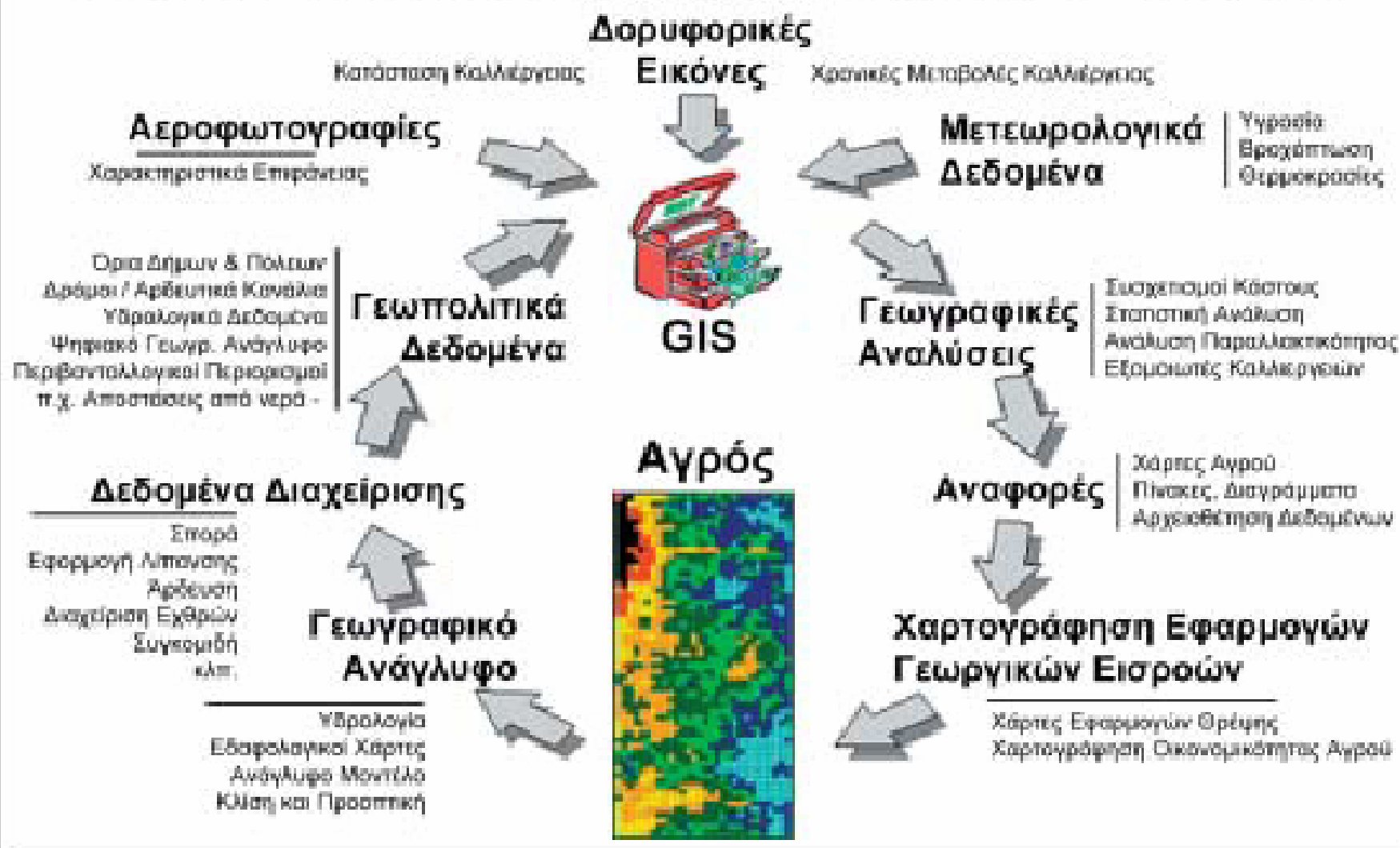

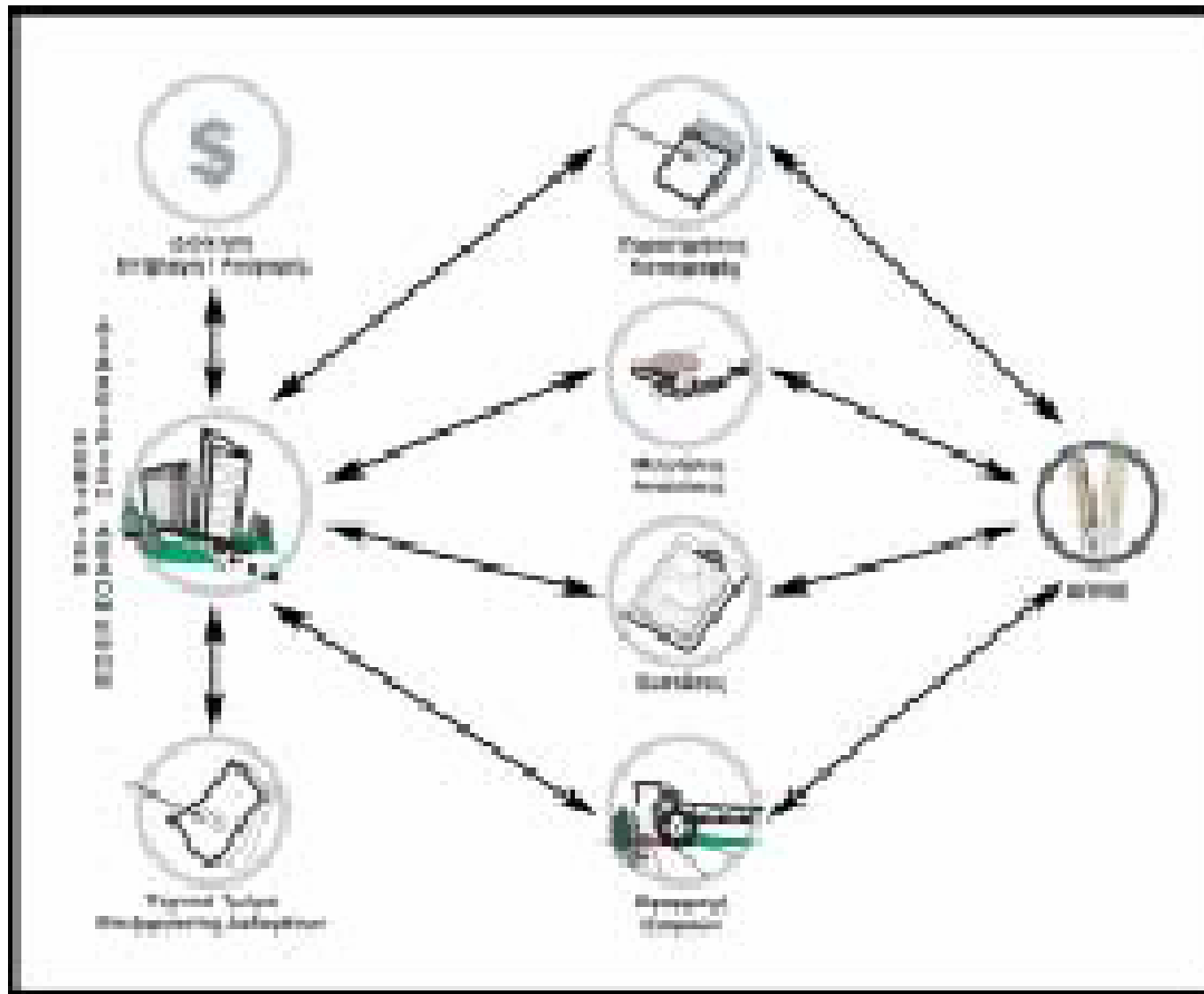

Εικ. 15. Ανάπτυξη της τεχνολογίας του SSToolbox σε πολυεπίπεδη εταιρική οργάνωση.

