



ΚΛΙΝΙΚΗ ΝΕΥΡΟΨΥΧΟΛΟΓΙΑ ΤΟΥ ΠΑΙΔΙΟΥ

Καθηγητής: Αργύρης Β. Καραπέτσας

Αξιολόγηση και Διάγνωση στη Νευροψυχολογία

Πότε προτρέχω στη Νευροψυχολογική Αξιολόγηση ;

Οι Νευροψυχολογικές Αξιολογήσεις γενικά προτείνονται στις ακόλουθες περιπτώσεις:

1. Περιπτώσεις που προσβάλουν το Κεντρικό Νευρικό Σύστημα (Τραύμα στο Κεφάλι, Ασθένειες του ΚΝΣ).
2. Χρόνιες και Σοβαρές Μαθησιακές Δυσκολίες οι οποίες δεν απαντώνται στην παραδοσιακή ειδική αγωγή ή τα θεραπευτικά προγράμματα, ειδικά όταν υπάρχουν στοιχεία από τύπους δεξιών ή αριστερών ημισυνδρόμων (πλαγίωση αισθητικο-κινητικών νευροβιολογικών ενδείξεων).
3. Σοβαρές συναισθηματικές ή συμπεριφορικές διαταραχές συνοδευόμενες από ειδικές μαθησιακές, νοητικές ή αναπτυξιακές καθυστερήσεις (π.χ. κίνηση, ομιλία/γλώσσα, αντίληψη) οι οποίες είναι ιδιαίτερα ανθεκτικές στην παραδοσιακή ψυχοφαρμακολογία, και τις ψυχολογικές ή συμπεριφορικές παρεμβάσεις.
4. Διαταραχές γνωστικές, ακαδημαϊκές, κινητικές, ομιλίας/γλώσσας, συμπεριφοράς και προσωπικότητας οι οποίες δεν μπορούν να εξηγηθούν από άλλες ψυχο-εκπαιδευτικές αξιολογήσεις.

1. Halstead-Reitan-Indiana Batteries for Children 1/1

Table 5.1. Subtests of the Halstead-Reitan Neuropsychological Test Batteries

FUNCTIONAL SKILLS	HALSTEAD-REITAN BATTERY (9-14 YEARS)	REITAN-INDIANA BATTERY (5-9 YEARS)
Motor Functions	Finger Tapping Grip Strength Tactual Performance Test (total time)	Finger Tapping Grip Strength Tactual Performance (total time) Marching Test
Visual-Spatial ^a	Trails Part A	Matching Figures Matching V's Matching Pictures Star Drawing Concentric Squares Target
Sensory-Perceptual	Tactile Perception Tactile Form Recognition Tactile Localization Fingertip Writing	Tactile Perception Tactile Form Recognition Tactile Localization Fingertip Writing
Alertness and Concentration ^b	Speech Sound Perception	Progressive Figures
Immediate Memory	TPT-Memory TPT-Localization	TPT-Memory TPT-Localization
Reasoning	Category Test Trails Part B	Category Test Color Form

^a Reitan includes Picture Arrangement, Block Design, and Object Assembly from Wechsler scales.

^b Reitan includes Coding from Wechsler scales.

1. Halstead-Reitan-Indiana Batteries for Children 2/8

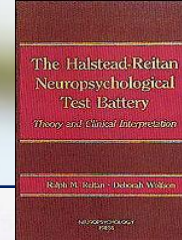
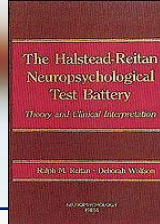

Table 5.2. Abilities Assessed by the HRNB and HINB in Children and Adolescents

FUNCTION	SUBTEST	REQUIREMENTS	R/L DIFFERENTIATION	ABILITIES	LOCALIZATION
Motor	Finger Tapping	HINB and NRNB: Children tap mounted key 5—10 second trials with dominant and nondominant hand	Dominant hand expected 10% faster	Motor speed and coordina- tion	Frontal lobe
Motor	Grip Strength	HINB and HRNB: Squeeze on dynam- ometer, alternate hands, 3 trials dominant/non- dominant	Dominant hand expected to be stronger	Sensitive to R/L weak- nesses in motor cortex	Frontal lobe
Motor	Tactual Performance Test (TPT)	HINB & HRNB: (a) Place 6 blocks onto board while blind- folded with dominant/ nondominant	Expect 1/3 improvement over trials	Motor and sensory functions, kinesthetic functions	Frontal lobe
Memory		(b) Draw location of blocks from memory	No	Spatial memory	Global
Visual	Trails A ^a	HRNB: Child connects circles sequentially as quickly as possible	No	Motor speed Visual- perception and symbol recognition	4

1. Halstead-Reitan-Indiana Batteries for Children 3/8



Sensory	Tactile Perception Test	HRNB and HINB: Back of hand and face are touched either separately or together with eyes closed	Errors on RH-implicates left hemisphere and LH errors implicate right hemisphere	Sensory stimulation	Contralateral parietal lobe
	Auditory Perception Test	Examiner stands behind child and lightly rubs fingers together. Child indicates where sound is (unilateral or bilateral presentations).	Yes	Auditory stimulation	Temporal lobe
	Visual Perception	Examiner produces a finger movement at eye level, above and below eye level.	Yes	Visual fields Peripheral, unilateral, and bilateral	Visual pathway Visual fields
	Tactile Form Recognition TRF	Child extends hand through opening in board, and a cross, square, or triangle is placed in hand.	Yes	Tactile form recognition (stereognosis)	Parietal lobe
	TRF	Child points to same shape on front of board.			

1. Halstead-Reitan-Indiana Batteries for Children 4/8

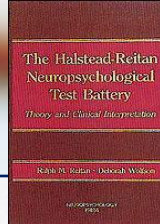
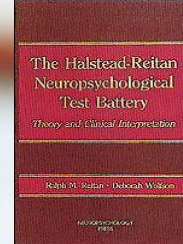

Table 5.2. (Continued)

FUNCTION	SUBTEST	REQUIREMENTS	R/L DIFFERENTIATION	ABILITIES	LOCALIZATION
Sensory (Continued)	Fingertip Writing (FTW)	HRNB: Numbers are traced on palm while child watches. Then, 3, 4, 5, and 6 are traced on fingertips with eyes closed. HINH: X's and O's are traced.	Yes	Tactile perception, attention can be a factor in performance.	Peripheral nervous system Parietal lobe
	Finger Localization Test	Examiner lightly touches each of child's fingers with eyes closed. Child indicates which finger was touched.	Yes. Errors on RH implicates left hemisphere and RH errors implicates right hemisphere.	Tactile perception discrimination and attention to tactile stimulation.	Unilateral errors implicate contralateral parietal lobe—can also occur with bilateral errors.
Alertness and Concentration	Speech ^a Sounds Perception Test	60 nonsense words presented on tape recorder. Child underlines correct sound from 4 alternatives.	No	Attention Auditory discrimination cross-modal matching.	Global Anterior left-hemisphere deficits (Teeter, 1986)
	Rhythm ^a	Thirty pairs of rhythms are presented on tape recorder. Child writes S or D if pair is same or different.	No	Attention, auditory perception, and concentration.	Global 6

1. Halstead-Reitan-Indiana Batteries for Children 5/8



Abstract Reasoning Logical Analysis	Category Test	80 items HINB, 168 items HRNB: Visual stimulus is projected on screen, and child selects one of four stimuli that corresponds to the original. If correct, bell rings. Incorrect: A buzzer sounds.	No	Abstract concept formation, mental efficiency and flexibility, learning skills.	Global Sensitive to right frontal lobe dysfunction in older children (Rourke et al., 1983)
	Trails B ^a	Series of circles alternating between letters (A—G) and numbers (1—8). Child connects circles alternating numbers-letters-numbers, etc.	No	Simultaneous processing, flexibility in planning.	Global
Language	Aphasia Screening Test	HRNB items: Naming, drawing, reading, math, and spelling.	Yes	Receptive language and expressive language, dyspraxia, word naming,	Language items relate to left hemisphere. Constructional items related to right hemisphere.

(Continued)

1. Halstead-Reitan-Indiana Batteries for Children 6/8

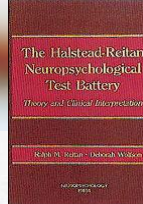
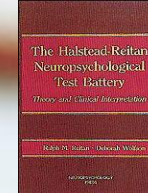

Table 5.2. (Continued)

FUNCTION	SUBTEST	REQUIREMENTS	R/L DIFFERENTIATION	ABILITIES	LOCALIZATION
Language (Continued)				reading, calculation, articulation, right/left discrimina- tion.	
<i>The following items are in HINB for younger children only:</i>					
Visual- Spatial	Matching Pictures	Matching pictures that are identical, then in same category.	No	Perception Generalization Reasoning	Global
	Matching V's and Figures, Concentric Square, and Star	Matching group of figures, or group of V's of differing widths; copying complex concentric square and star	No	Visual- perception and motor abilities.	Association areas
	Target Test	Consists of large cardboard poster with nine printed dots. Examiner taps out a series of dots and after 3-second delay child repro- duces series on protocol.	No	Visual and spatial memory abilities.	Association areas

1. Halstead-Reitan-Indiana Batteries for Children 7/8



Motor	Marching Test	Child follows a sequence of circles connected by lines up a page touching each circle as quickly as possible, using right, left, and both hands.	Yes	Gross motor function and coordination	Global
Alertness and Concentration	Progressive Figures	8 large shapes with small shapes inside. Child moves from the small shape inside to a large figure with same shape.	No	Visual perception, motor speed, concentration, and cognitive flexibility	Global
Reason	Color Form Test	Geometric shapes of different colors on board. Child touches one figure then another, moving from shape-color-shape-color, etc.	No	Simultaneous processing and flexibility in planning	Global

Note: Reitan Indiana Neuropsychological Battery (HINB); Halstead-Reitan Neuropsychological Battery (HRNB).

^aIn HRNB for older children only.

1. Halstead-Reitan-Indiana Batteries for Children 8/8

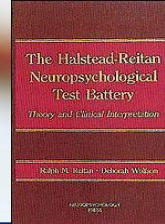

Table 5.3. Right–Left Sensory and Motor Signs on the Halstead-Reitan Neuropsychological Test Battery

MOTOR AND SENSORY ITEMS	LEFT-HEMISPHERE SIGNS ^a	RIGHT-HEMISPHERE SIGNS
Finger-tapping	Lower right hand tapping	Lower left hand tapping
Tactual performance test	Lower right hand scores	Lower left hand scores
Grip strength	Lower right hand scores	Lower left hand scores
Finger localization	Higher errors–right hand	Higher errors–left hand
Fingertip writing	Higher errors–right hand	Higher errors–left hand
Tactile perception	Higher errors–right hand	Higher errors–left hand

Note: Right-dominant individuals.

^aDivide nondominant hand by dominant hand and subtract from 1. Use Neuropsychological Deficit Scale to determine significant differences between right and left hands.



2. Luria Nebraska Assessment Procedures for Children 1/2



Table 5.5. Major Systems and Behavioral Correlates of Luria's Functional Units

FUNCTIONAL SYSTEMS	BRAIN UNITS	BEHAVIORAL CORRELATES
Unit 1: Arousal System	Reticular activating system pons and medulla through thalamus to cortex	Modulate cortical arousal Filters incoming stimuli Attention and concentration
Unit 2: Sensory System	Primary temporal lobes Secondary temporal lobes	Auditory perception Analysis and synthesis acoustic sounds and sequential analysis Phoneme, pitch, tone, and rhythm
	Primary parietal lobes Secondary parietal lobes	Tactile perception Two-point discrimination Movement detection Recognition of complex tactile stimuli (e.g., shapes)
	Primary occipital lobes Secondary occipital lobes	Visual perception Visual discrimination (letters, shapes, etc.) Cross-modal integration
	Tertiary parietal occipital/ temporal region	Simultaneous processing "Intelligence" (e.g., reading, writing, math, language, syntax, grammar, stereognosis, spatial rotation, angle discrimination)
Unit 3: Output/Planning	Primary frontal lobes Secondary frontal lobes	Simple motor output Sequencing motor activity Speech production Decision making and evaluation Impulse control
	Tertiary frontal lobes	Delay of gratification Focused attention

2. Luria Nebraska Assessment Procedures for Children 2/2



Table 5.6. Developmental Sequences of Luria's Functional Units

DEVELOPMENTAL STAGE	AGE RANGES	FUNCTIONAL SYSTEMS	DEFICITS/DAMAGE
Stage 1	Birth—12 months	Arousal Unit 1	Disorders of arousal Physiological hyperactivity Death in some severe cases Severe retardation
Stage 2	Birth—12 months	Primary zones Sensory Unit 2	Sensory-motor deficits in contra- lateral hemisphere
Stage 3	Birth—5 years	Secondary zones Sensory Unit 2	Hemispheric differentiation (language—left hemisphere) Damage prior to 2 years—some transfer of function Small injury—no transfer Diffuse injury—no transfer Single modality deficits
Stage 4	5—8 years	Tertiary zones Sensory Unit 2	Learning deficits Mental retardation Learning disabilities
Stage 5	Adolescence— 24 years	Tertiary zones Unit 3	Frontal lobe symptoms

2. Luria Nebraska Neuropsychological Battery – Children's Revision

Κλινικές Κλίμακες:

1 • Motor

2 • Rhythm

3 • Tactile

4 • Visual

5 • Receptive Speech

6 • Expressive Language

7 • Writing

8 • Reading

9 • Arithmetic

10 • Memory

11 • Intelligence



1. Stroop Color Word Test

2. Wisconsin Card sorting Test (WCST)

3. Wide Range Assessment of Memory and Learning (WRAML)

4. Rey-Osterreith Complex Figure Test

Tests of Reasoning

1. Stroop Color Word Test

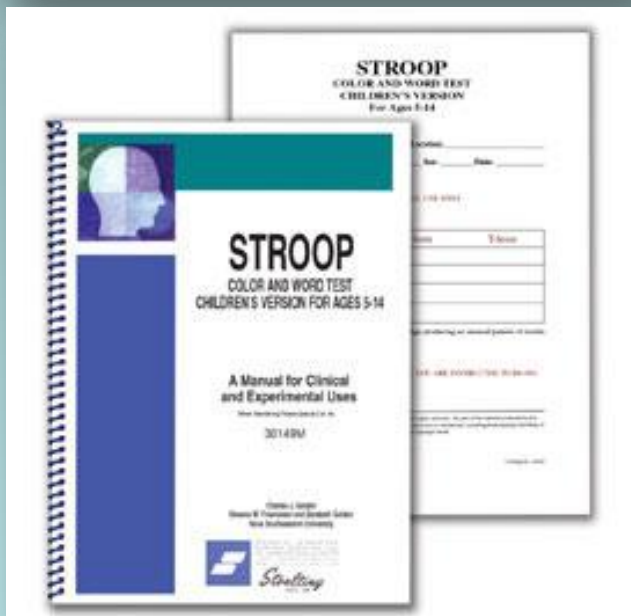

2. Wisconsin Card sorting Test (WCST)

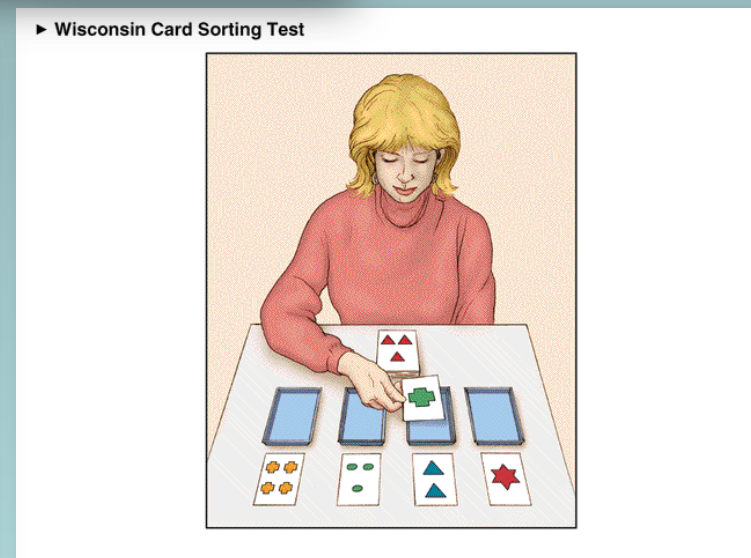
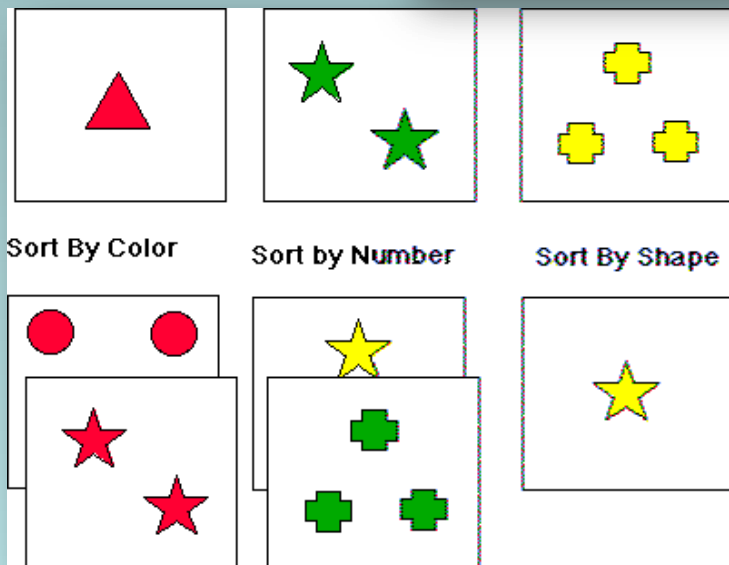
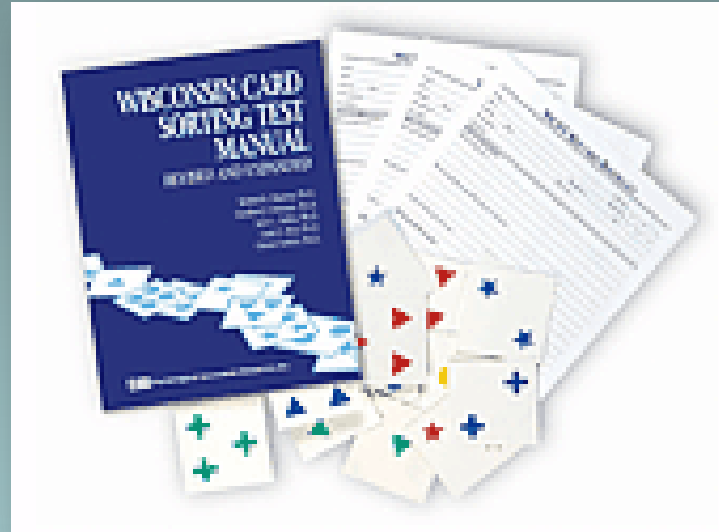

3. Wide Range Assessment of Memory and Learning (WRAML)



4. Rey-Osterreith Complex Figure Test



Figura 1. Figura Complexa de Rey.

Tests of Verbal Language and Memory

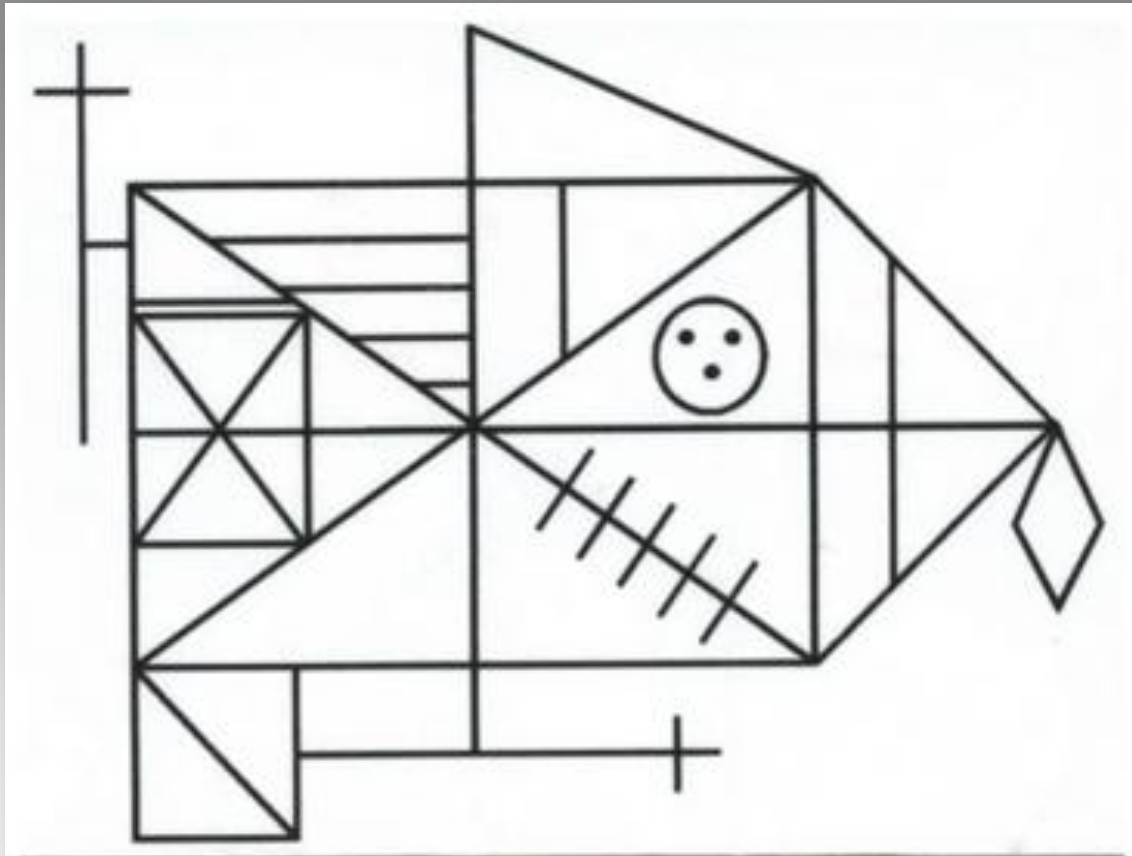

Boston Naming Test (*BNT*)

Controlled Oral Word Association Test (*COWA*)

California Verbal Learning Test (*CVLT-C*)

Neurosensory Center Comprehensive Examination for Aphasia

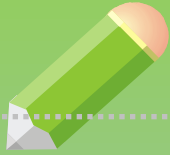

California Verbal Learning Test (CVLT-C)





Tests of Perception

1. Hooper Visual Organization Test

2. Benton Visual Perceptual Tests

3. Judgment of Line Orientation

4. Test of Facial Recognition

5. Cancellation Tasks





1. Hooper Visual Organization Test



2. Benton Visual Perceptual Tests

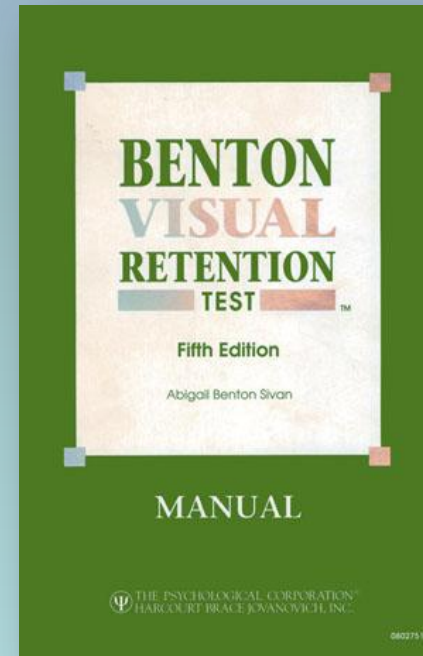
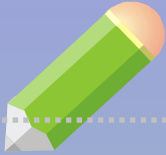

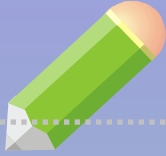

3. Judgment of Line Orientation

An example of an item from the Judgement of Line Orientation Test (Benton, Hamsher, Varney, & Spreen, 1983)

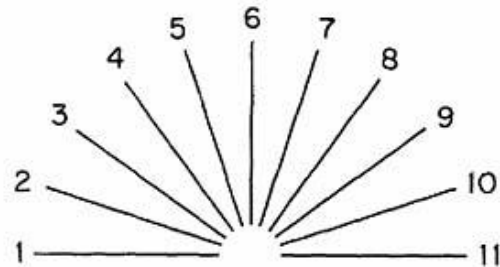

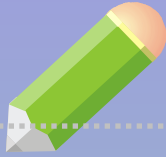

5. Cancellation Tasks

a

Task	a1, a2	a3	b	c1,c4	c2,c5	c3
Target						
Distractor						

b

Πεδία Νευροψυχολογικής Αξιολόγησης και Προτεινόμενες

Δοκιμασίες 1/2

Table 5.11. Domains for Neuropsychological Assessment and Suggested Measures

GROSS MOTOR	FINE MOTOR	VISUAL-PERCEPTUAL
Marching (HINB) Motor Scale (MSCA) Motor Scale (LNNB-CR) Grip Strength Test	Grooved Pegboard Purdue Pegboard Finger Tapping Tactual Performance Test Bender-Gestalt Test Trails A Rhythm (LNNB-CR)	Matching Figures, V's, Concentric Squares, and Stars (HINB) K-ABC subtests Rey-Osterreith Complex Figure Judgment of Line Test Facial Recognition Bender-Gestalt Test Beery Visual-Motor Integration Test Hooper Visual Organization Test
SENSORY-MOTOR	VERBAL FLUENCY	EXPRESSIVE LANGUAGE
Tactile, Visual, Auditory (HRNB, HINB) Tactile Form Recognition Fingertip Writing (HRNB, HINB)	Controlled Oral Word Association-FAS Verbal Fluency (MSCA)	Clinical Evaluation of Language Fundamentals (CELF-R) Vocabulary Subtest (SB:FE & WISC-III) Boston Naming Test Aphasia Screening Test (HRNB)

Πεδία Νευροψυχολογικής Αξιολόγησης και Προτεινόμενες

Δοκιμασίες 2/2

RECEPTIVE LANGUAGE	MEMORY	ABSTRACTION/REASONING
CELF-R Token Test Peabody Picture Vocabulary–Revised Picture Vocabulary (WJ-R)	Benton Visual-Retention Tactual Performance Test Wide Range Assessment of Memory and Learning (WRAML) Children’s Auditory Verbal Learning Test (CAVLT) Rey Auditory Verbal Learning Test Sentence Memory (SB:FE)	Category Test (HRNB, HINB) Wisconsin Card Sort (WCST) Concept Formation Test (WJ-R) Trails B (HRNB) Color Form Test (HINB) Ravens Progressive Matrices
LEARNING	EXECUTIVE FUNCTIONS	ATTENTION
CAVLT WRAML Rey-Auditory Verbal Learning Test Auditory-Verbal Learning (WJ-R)	Wisconsin Card Sort Category Test Matching Familiar Figures (HINB) Verbal Fluency Tasks	Continuous Performance Test Cancellation Tests (WJ-R; D2) Stroop Test Seashore Rhythm Test (HRNB) Speech-Sounds Perception Test (HRNB) Progressive Figures Test (HINB) Serial 7’s

Note: Halstead-Indiana Neuropsychological Battery (HINB); Halstead-Reitan Neuropsychological Battery for Children (HRNB); Kaufman Assessment Battery for Children (K-ABC); Luria Nebraska Neuropsychological Battery–Children Revised (LNNBB-CR); McCarthy Scales of Children’s Ability (MSCA); Stanford-Binet Intelligence Scale, Fourth Edition (SB:FE); Woodcock-Johnson Cognitive Battery–Revised (WJ-R); Wechsler Intelligence Scales for Children–Third (WISC-III).



Νοητική, Γνωστική και Αντιληπτική Λειτουργία

(Intellectual, Cognitive & Perceptual Functioning)

Woodcock-Johnson Tests of Cognitive Ability-Revised (*WJR*)

1

Wechsler Intelligence Scale for Children-III (*WISC-III*)

2

Differential Ability Scale (*DAS*)

3

Kaufman Assessment battery for Children (*K-ABC*)

4

1

Woodcock-Johnson Tests of Cognitive Ability-Revised (WJR)

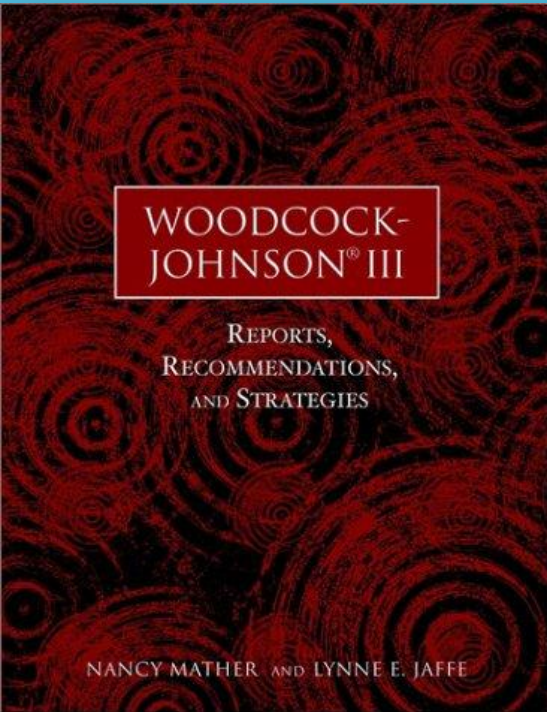

WOODCOCK JOHNSON® III

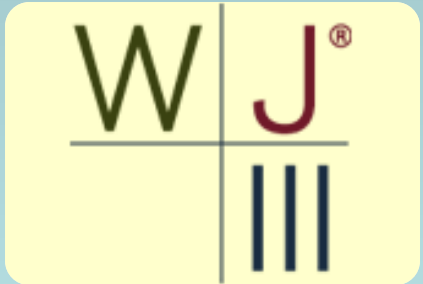

Wechsler Intelligence Scale for Children-III (*WISC-III*)



3

Differential Ability Scale (*DAS*)



4

Kaufman Assessment battery for Children (*K-ABC*)

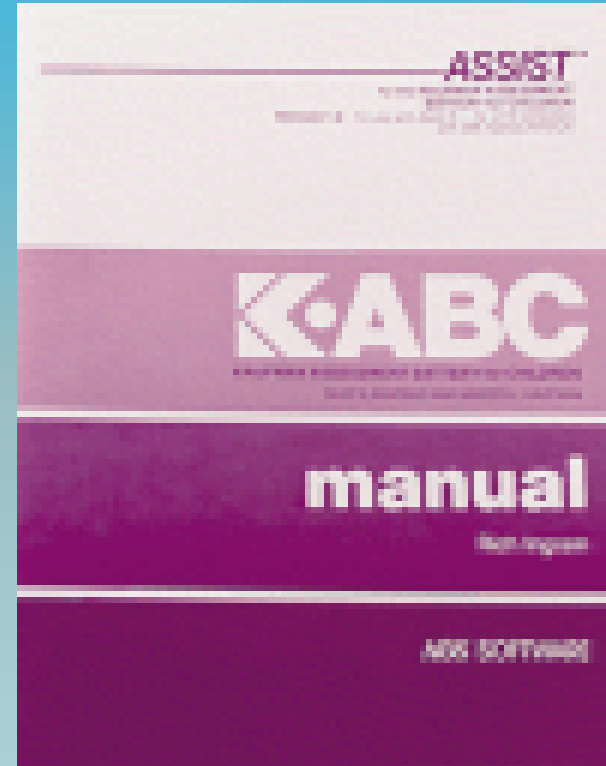

B.

Σχολική Επίδοση (*Academic Functioning*)

1.

Woodcock-Johnson Tests of Cognitive Ability-Revised
(WJR)

2.

Wechsler Individual Achievement Test (WIAT)

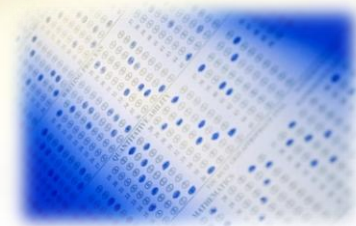

1.

1. Woodcock-Johnson Tests of Cognitive Ability-Revised (WJR)

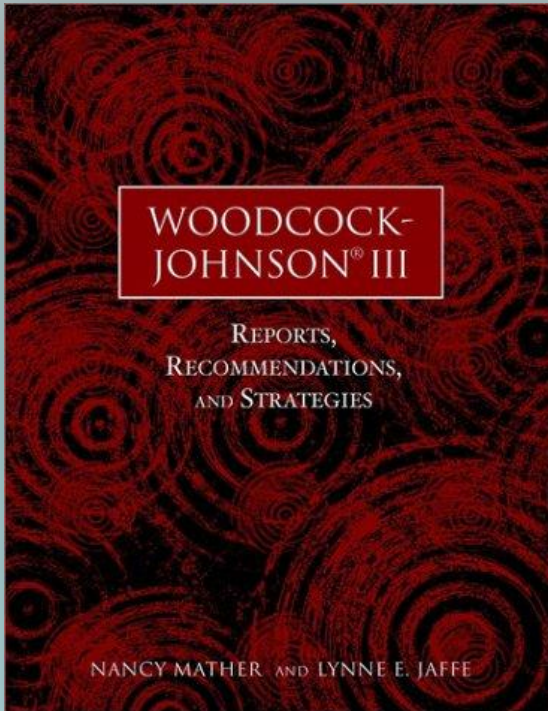

WOODCOCK JOHNSON® III



2.

Wechsler Individual Achievement Test (WIAT)



Γ.

Ψυχοκοινωνική Λειτουργία (*Psychosocial Functioning*)

Child Behavior Checklist (*CBL*)

Behavior Assessment System for Children (*BASC*)

Personality Inventory for Children (*PIC*)

Social Skills Questionnaire (*SSQ*)

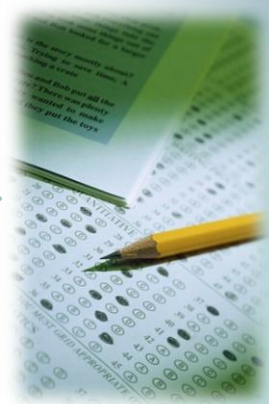



Behavior Assessment System for Children (*BASC*)

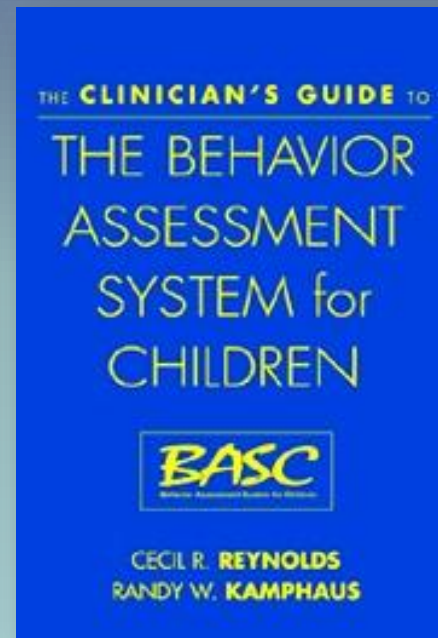

Personality Inventory for Children (*PIC*)





Ηλεκτροφυσιολογικές και Νευροαπεικονιστικές Τεχνικές στην Νευροψυχολογία

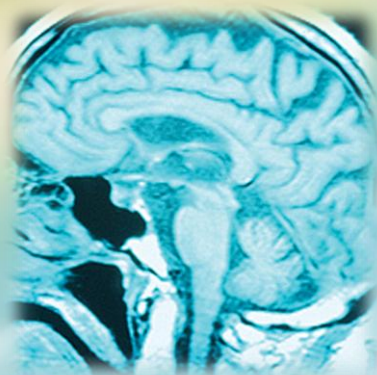



A.

ΗΛΕΚΤΡΟΦΥΣΙΟΛΟΓΙΚΕΣ ΤΕΧΝΙΚΕΣ

(ELECTROPHYSIOLOGICAL TECHNIQUES)

1. Electroencephalography (EEG)

2. Evoked Potentials (EPs)

3. Event-Related Potentials (ERPs)

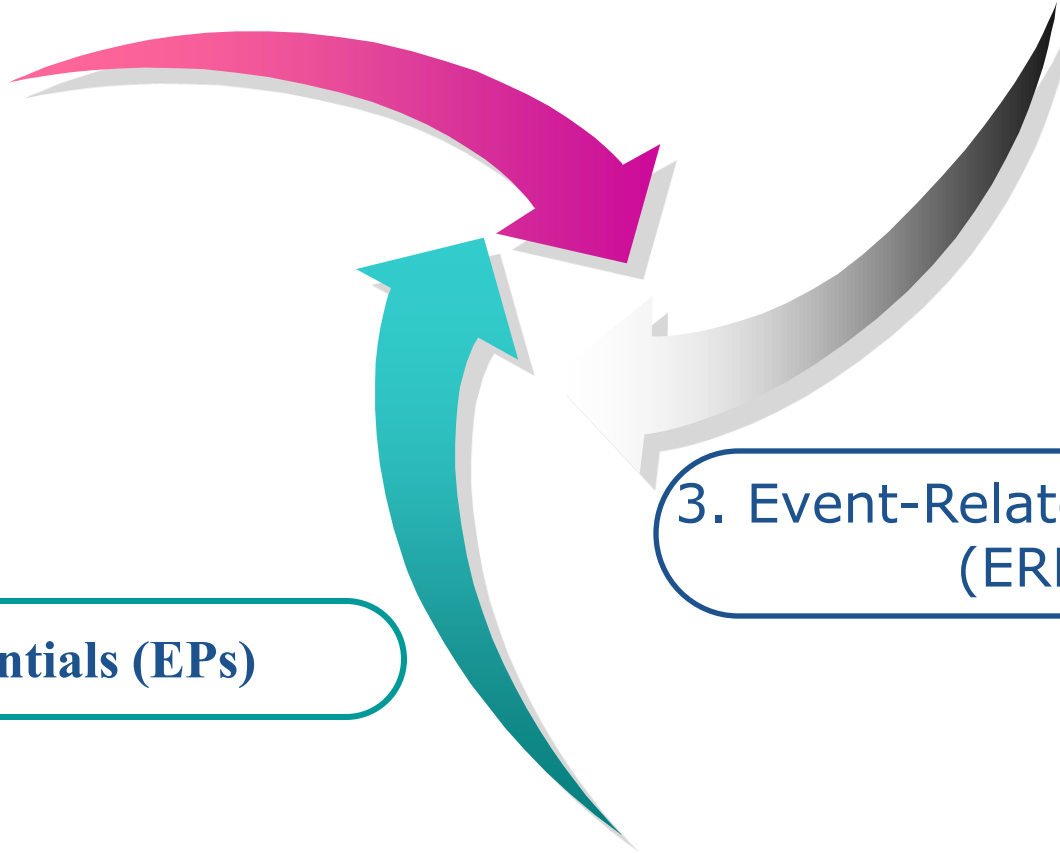



1. Electroencephalography (EEG)

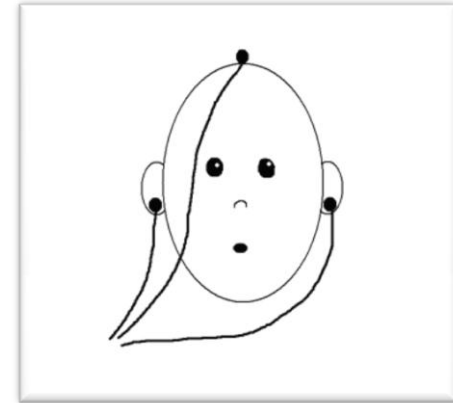
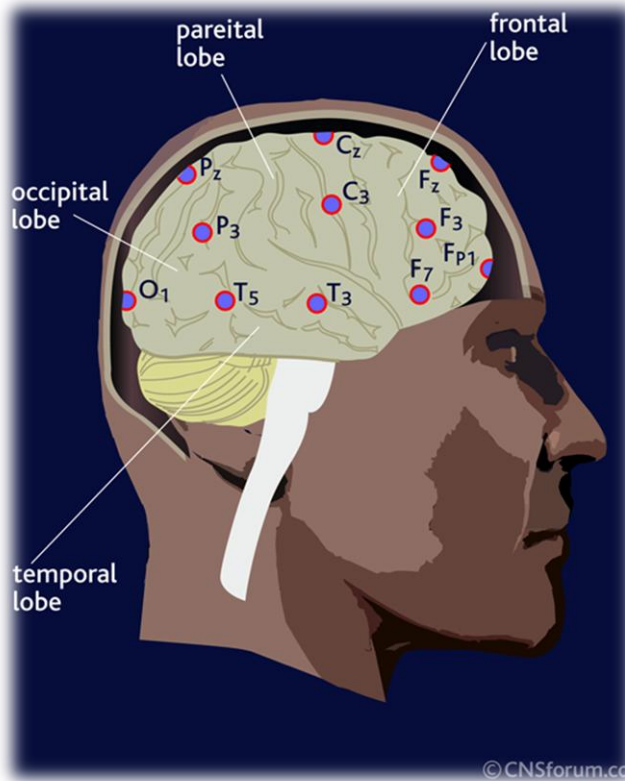



2. Evoked Potentials (EPs)

1. Ακουστικά προκλητά δυναμικά (Auditory evoked potentials – **AEPs**)

2. Οπτικά προκλητά δυναμικά (Visual evoked potentials – **VER**)

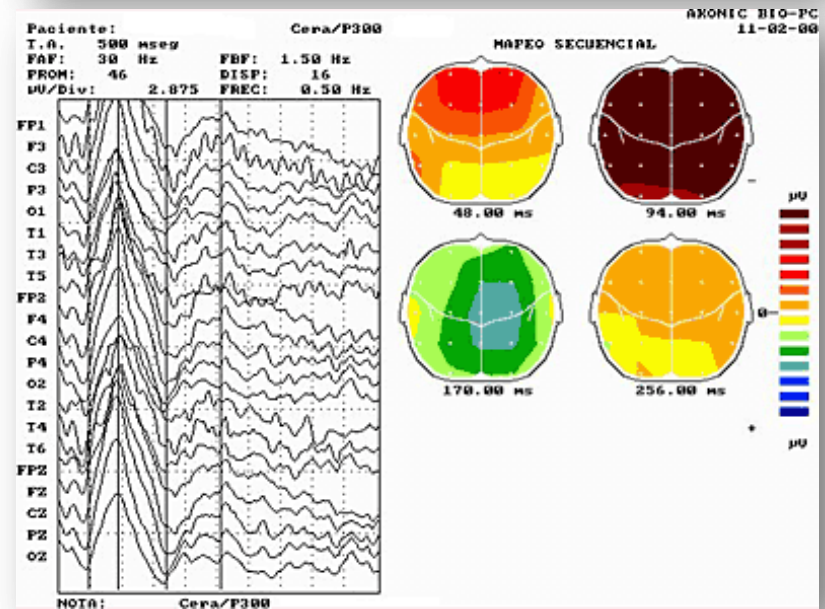
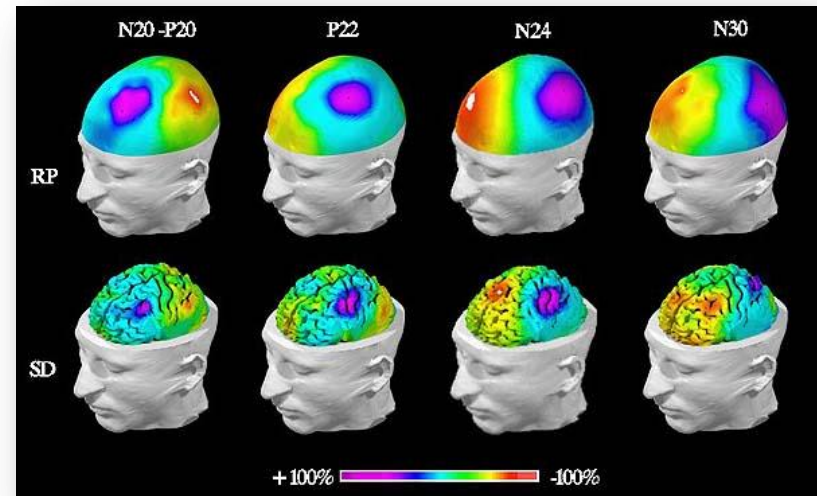



3. Event-Related Potentials (ERPs)

- **exogenous**
- **endogenous**
- **P300**
- **MMN**
- **Processing Negativity**



left side

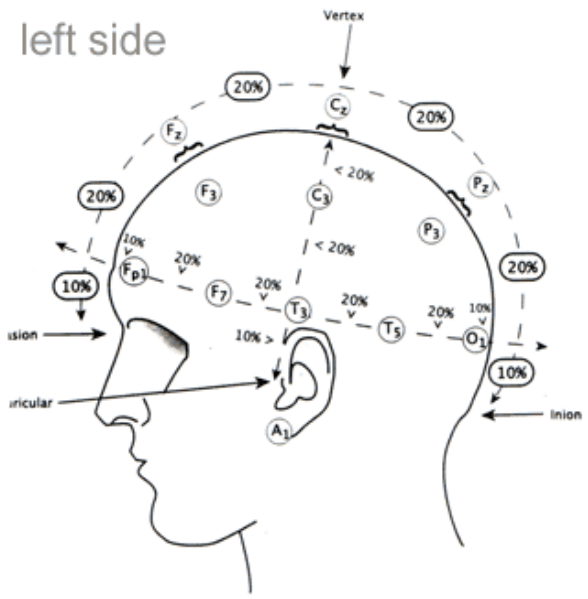

top

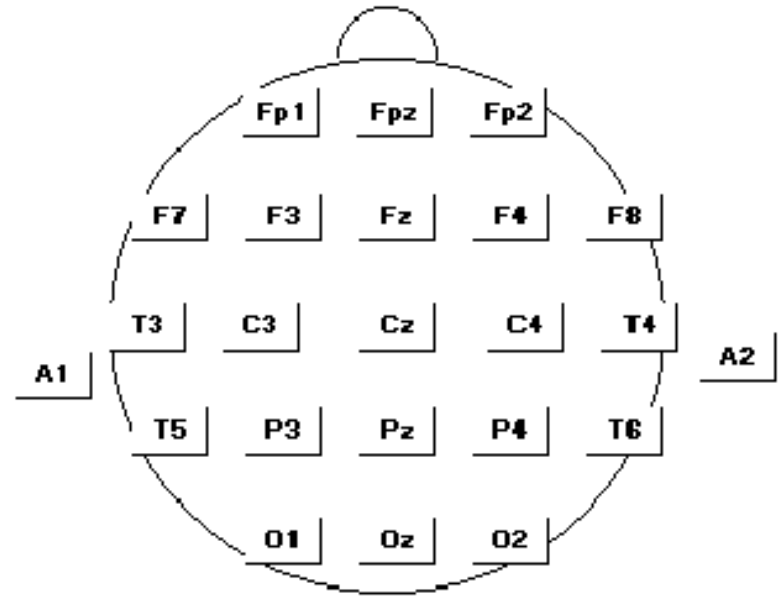
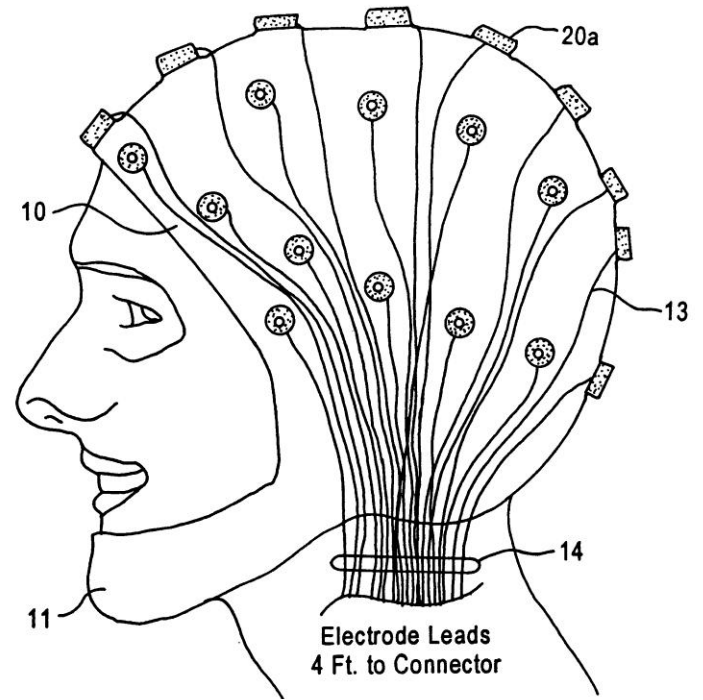
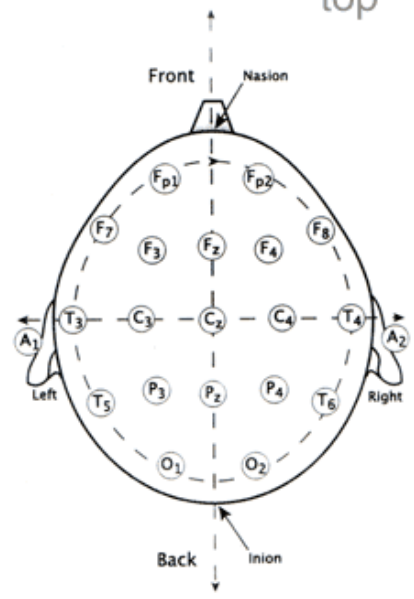

Relationship between brain and electrode positions

ELECTRODE PLACEMENT

International 10-20 System



B.

Νευροαπεικονιστικές Τεχνικές (*Neuroimaging Techniques*)

1. Computed Tomography (*CT*)

2. Magnetic Resonance Imaging (*MRI*)

3. Functional Magnetic Resonance
Imaging (*fMRI*)



1

Computed Tomography (CT)

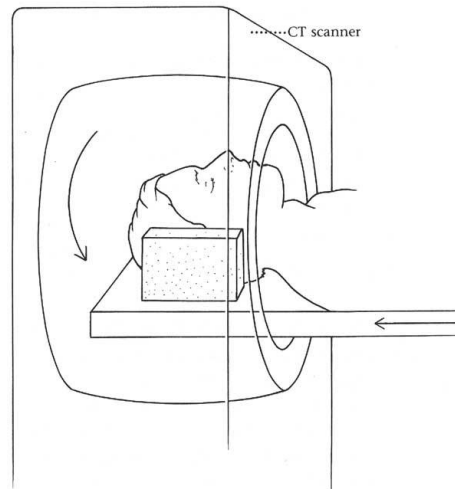
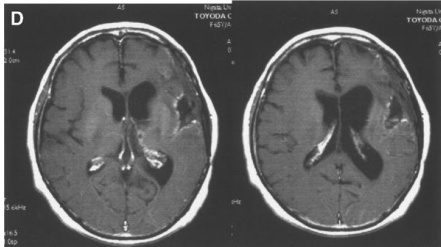
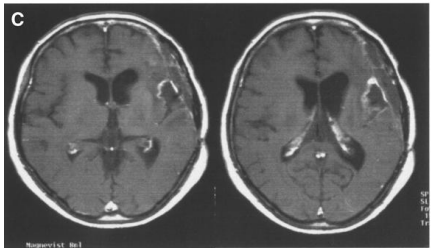
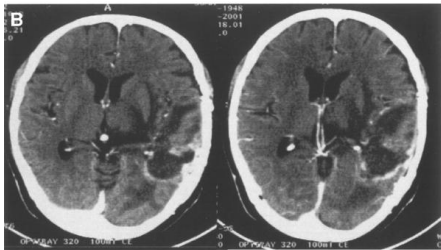
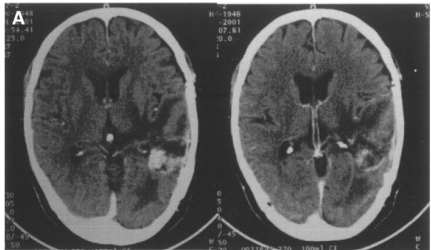

Wendolyn Hill

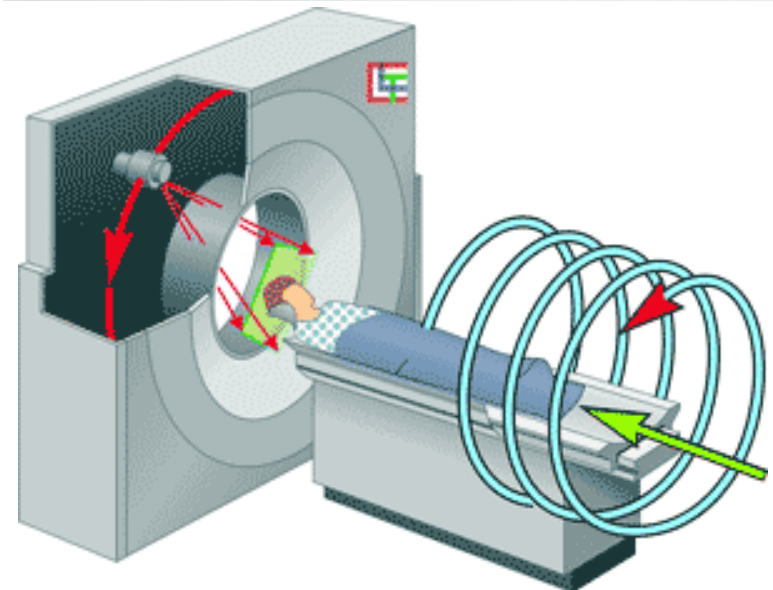



2

Magnetic Resonance Imaging (MRI)

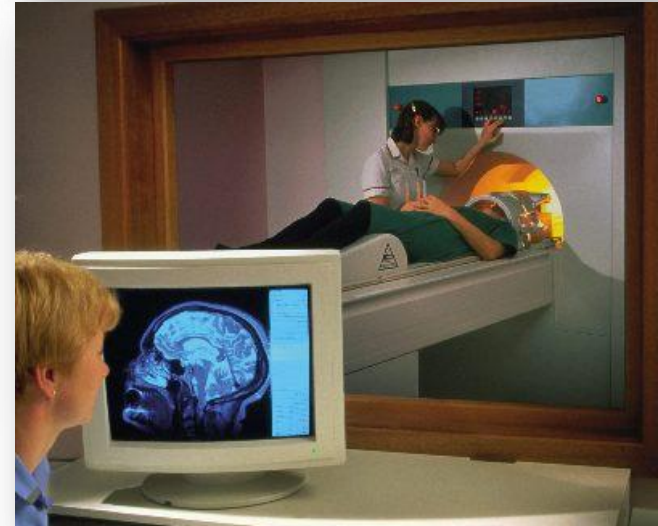
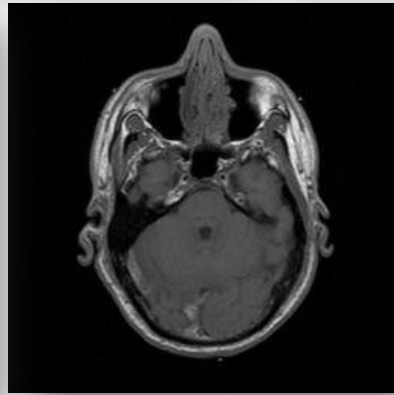
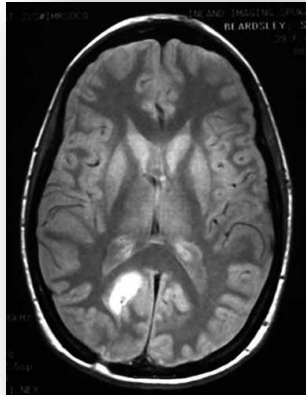
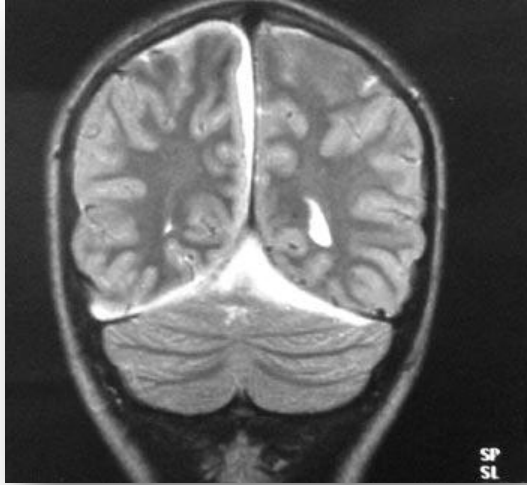



3

Functional Magnetic Resonance Imaging (fMRI)

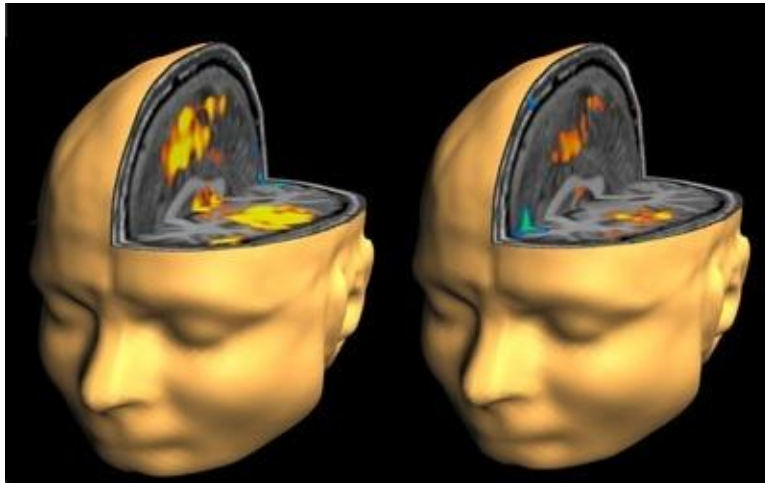
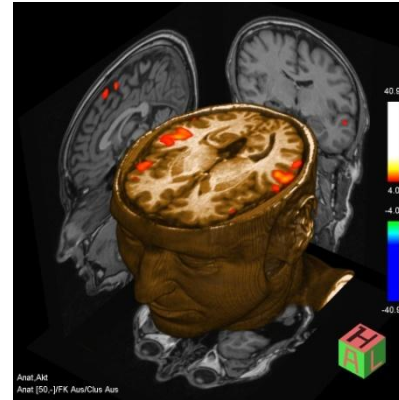
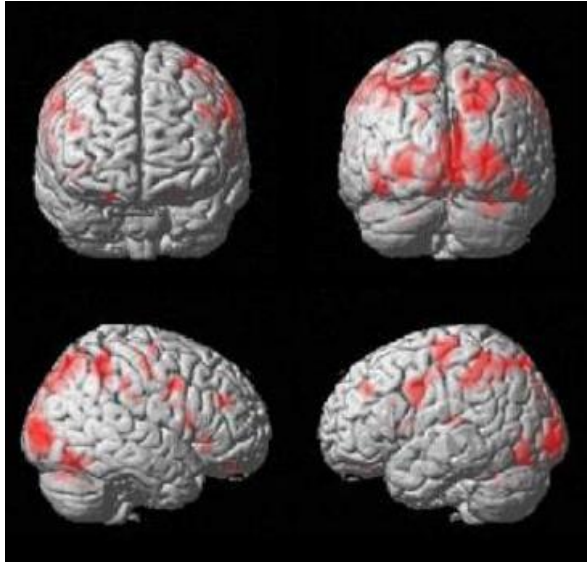



Νευροραδιολογικές Τεχνικές

*Neuroradiological
Techniques*

**1. Positron
Emission
Tomography
(PET)**

**2. Single Photon
Emission
Tomography
(SPECT)**



1

1. Positron Emission Tomography (PET)

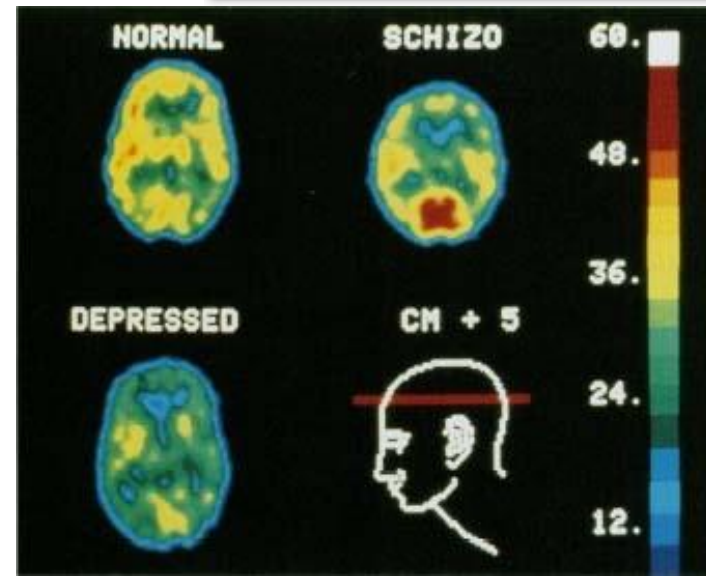
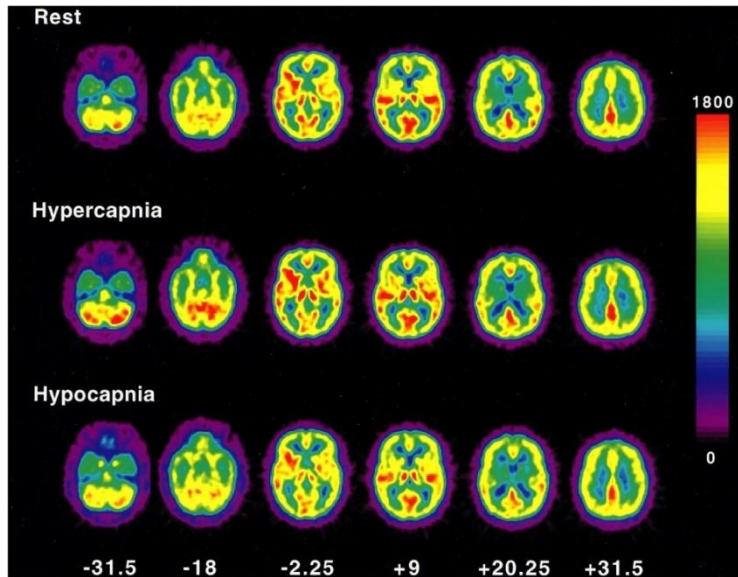
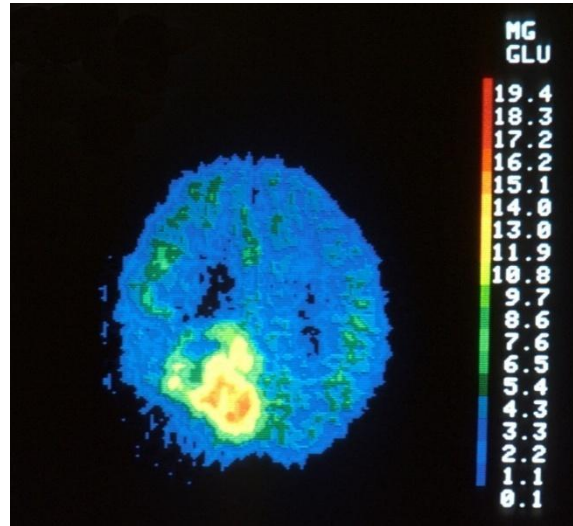
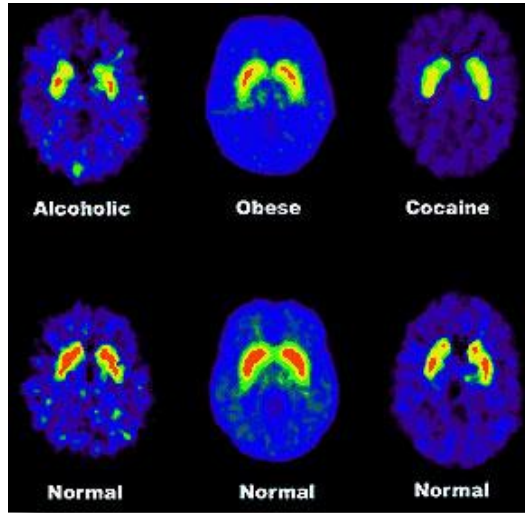



2

Single Photon Emission Tomography (SPECT)

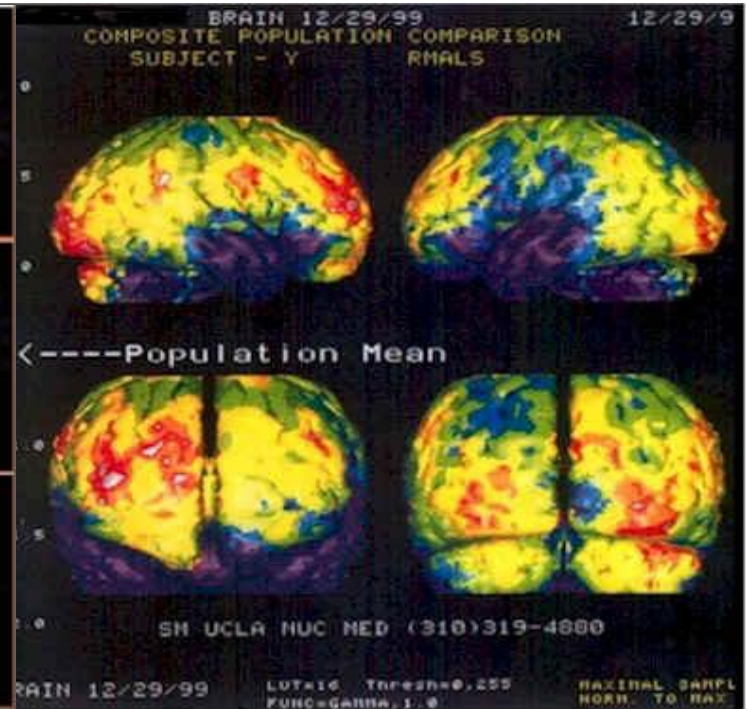
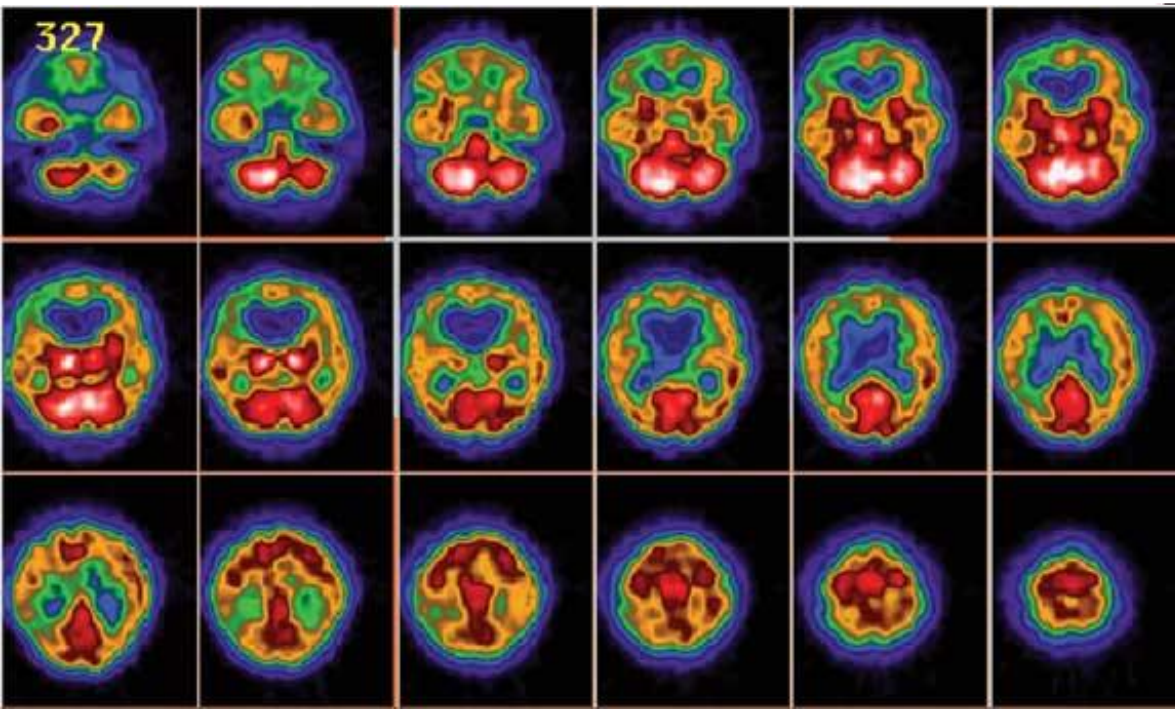

Άλλες Τεχνικές Νευροψυχολογικής Αξιολόγησης

Magnetic Resonance Spectroscopic Imaging (*MRSI*)

Magnetoencephalography (*MEG*)

Computerized axial tomography (*C.A.T.*)

nuclear- Magnetic- resonance (*NMR*)

Brain electrical activity mapping (*BEAM*) + computer *EEG*

Electrochoc (*ECT*)

Biofeedback Training

Ηλεκτρομυογράφημα

Ηλεκτρονυσταγμογράφημα



Magnetoencephalography (MEG)





Computerized axial tomography (C.A.T.)

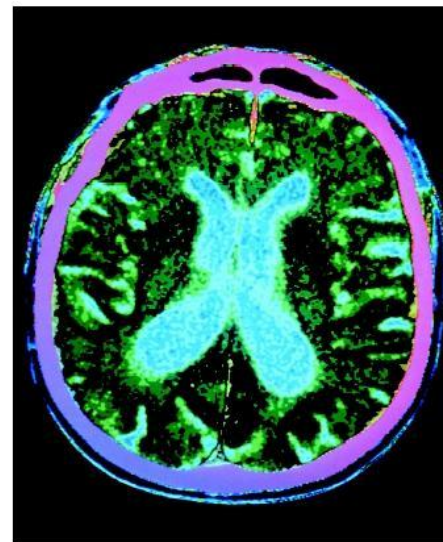
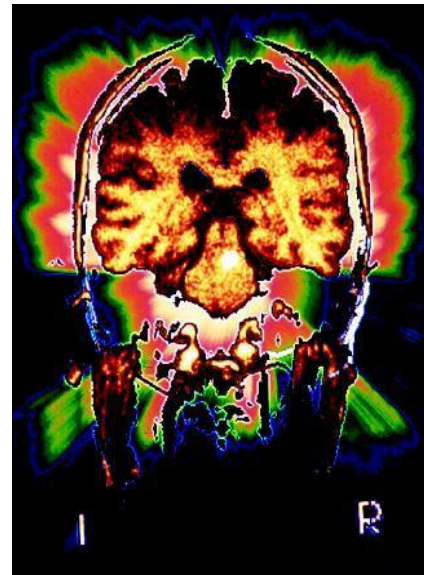

Brain electrical activity mapping (BEAM) + computer EEG

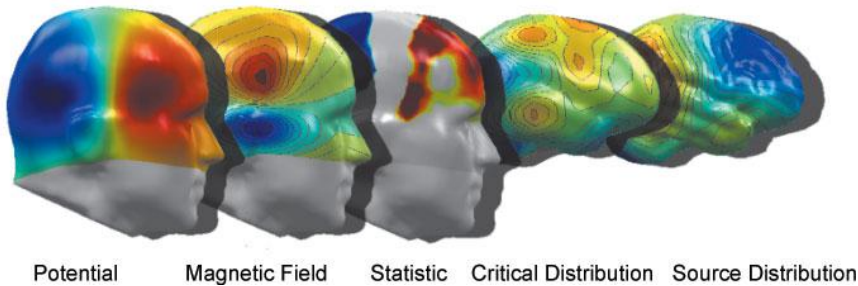
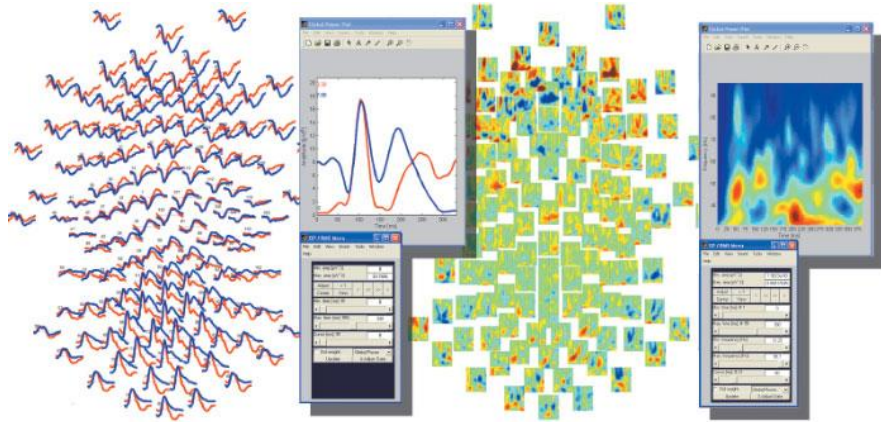

Potential Magnetic Field Statistic Critical Distribution Source Distribution

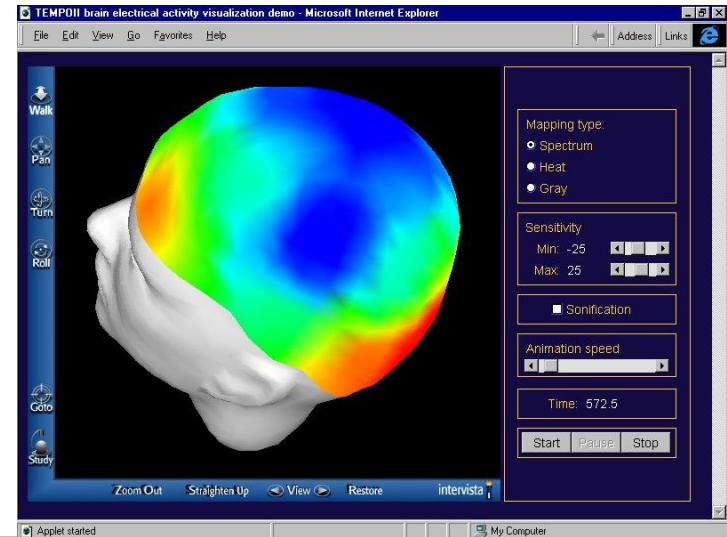
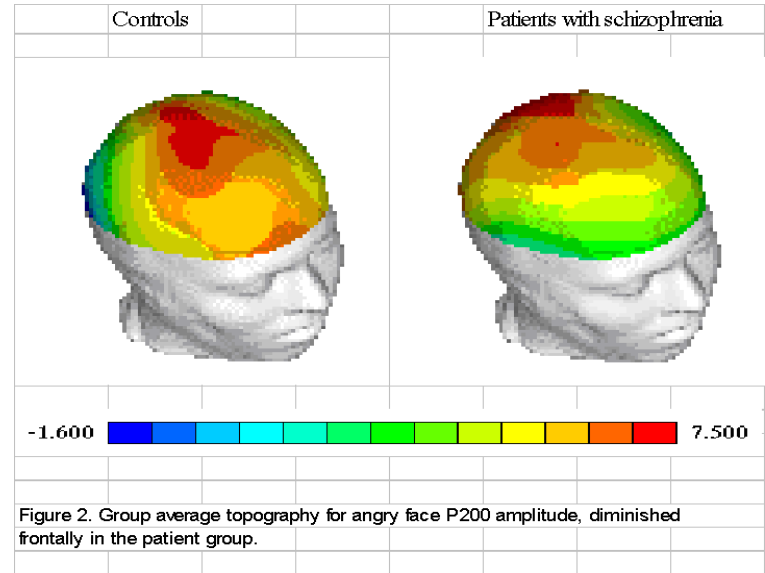



Electrochoc (ECT)

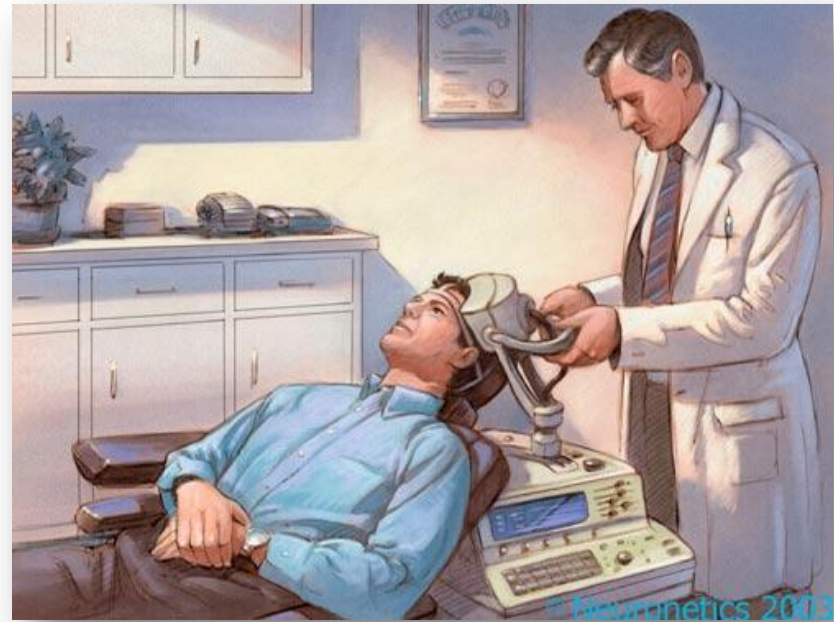

Biofeedback Training





Ηλεκτρομυογράφημα

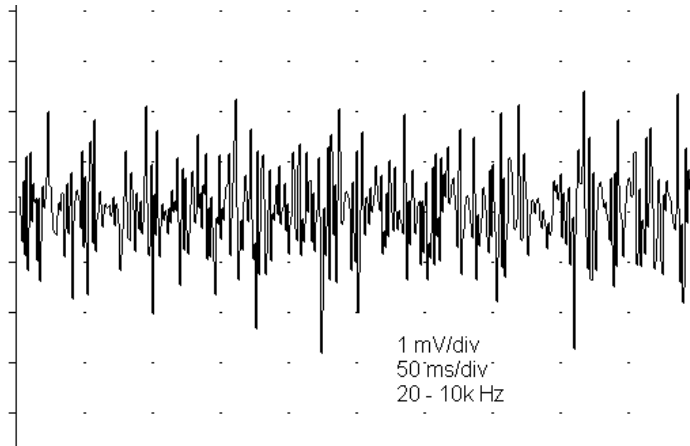
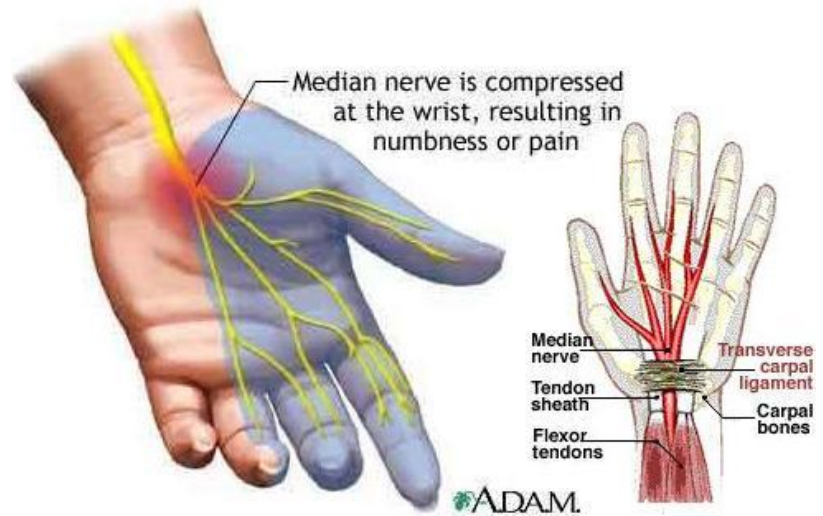



Ηλεκτρονυσταμογράφημα



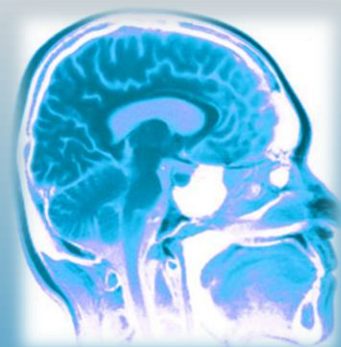

© Original Artist
Reproduction rights obtainable from
www.CartoonStock.com



"We've given you a brain scan and
we can't find anything."

