

● ● ● | Acoustic insulation

Nicolas REMY

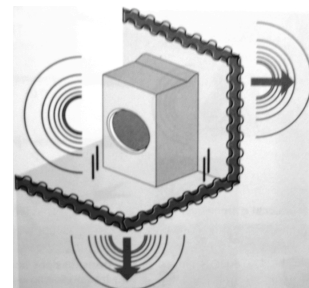

● ● ● | Noise categories



We consider two categories of noises

- Airborne noises : propagation through the air
  - Human voices, TV, hifi stereo system..
- Structure borne noises : propagation inside the building structure.
  - People walking on a floors, furnitures moved, elevator, fluids through pipes...
- Be careful : most of the time we can hear mix of the 2 categories of sounds. For example, when ones snaps a door inside a building, we can hear sounds transmitted by the air and by the structure.



## Sound transmission between two rooms

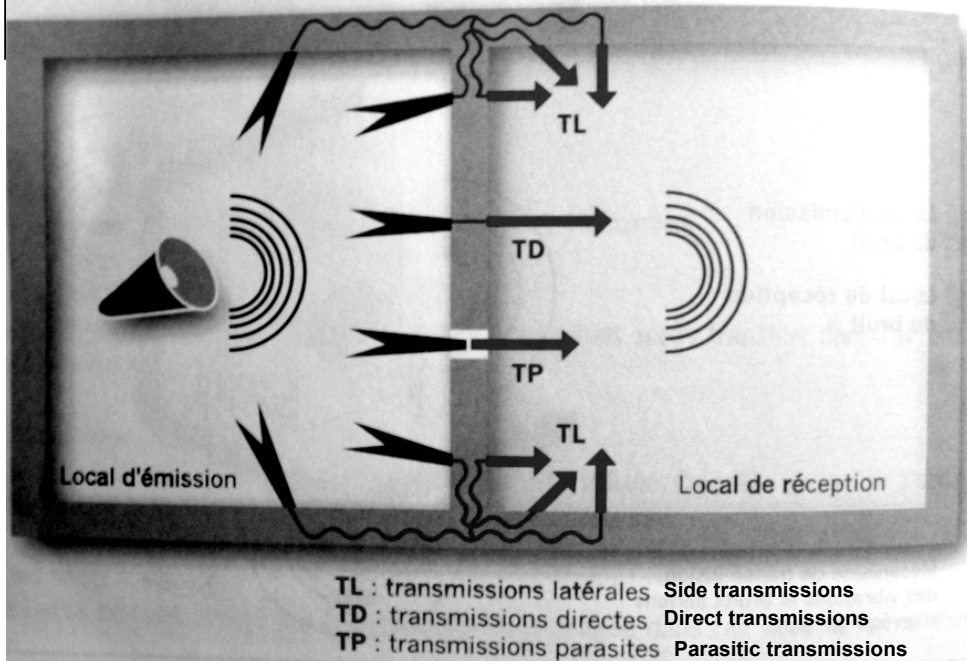

3



## Airborne Noises

- o Airborne noise insulation between 2 rooms depends on the acoustic parameter of the wall given by the ***R* or *R<sub>w</sub>*, noise attenuation index.**
- o ***R<sub>w</sub>* is given by octave or 1/3octave and measured in laboratory.**

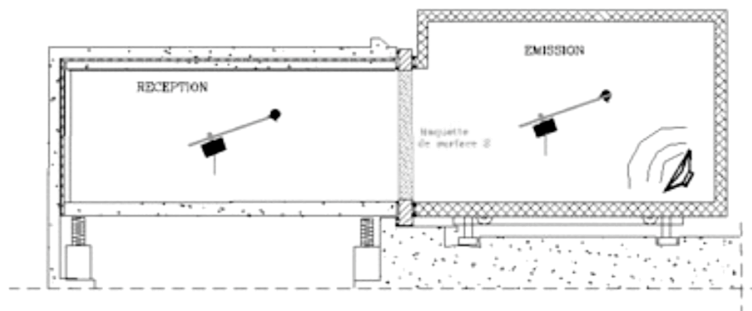

4

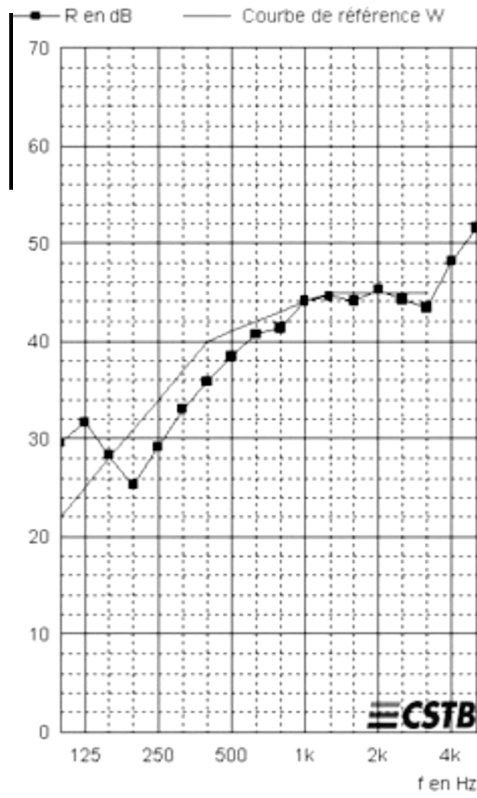

f	R
100	29,6
125	31,7
160	28,3
200	25,3
250	29,2
315	33,0
400	35,8
500	38,4
630	40,7
800	41,3
1000	44,1
1250	44,6
1600	44,1
2000	45,3
2500	44,2
3150	43,4
4000	48,2
5000	51,6
Hz	dB

$R_w (C; C_v) = 41(-2; -5) \text{ dB}$

**Ordre de grandeur**

Code	Produit	kg/m <sup>2</sup>	R <sub>w</sub>
BA 10	Béton de 10 cm	220	50
BA 20	Béton de 20 cm	470	60

# Regulations

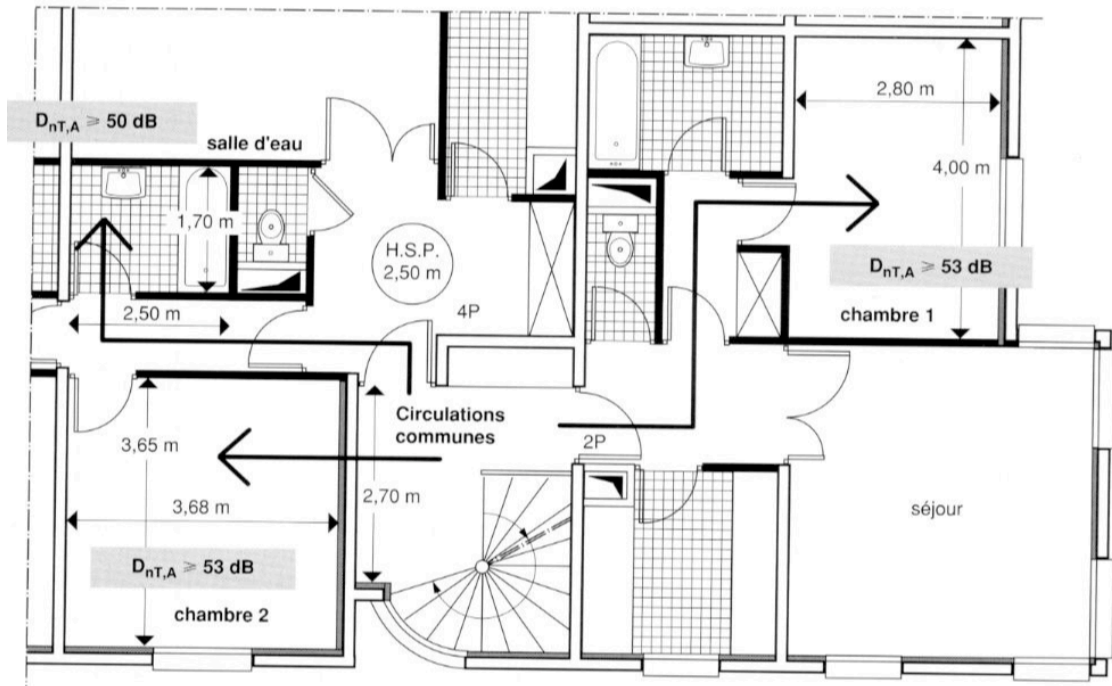



## Airborne Noises

### o **R** ou **R<sub>w</sub>** : **Noise attenuation Index**

- rise with frequencies
- rise with mass (4dB more every time you double the mass).

If you choose a material of 500kg/m<sup>2</sup> instead of a 250kg/m<sup>2</sup>, you will increase the R<sub>w</sub> by 4dB.

### o 2 plasterboards on a metal framework 48Kg/m<sup>2</sup> de 14cm

- R<sub>w</sub> = 60 dB = wall with 450 kg/m<sup>2</sup> mass

### o Be careful of resonance

7



## Noise attenuation Index

Wall weakness

Noise attenuation index for a wall in concrete 20cm thickness with 460kg/m<sup>2</sup>.

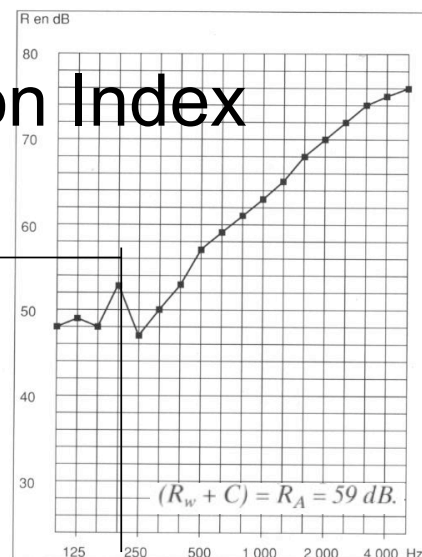

Tab. 1.1 – Indices d'affaiblissement acoustique pondérés de diverses parois.

Nature de la paroi	$(R_w + C) = R_A$ (dB)	$(R_w + C_{tr}) = R_{A,tr}$ (dB)
Bloc de béton plein perforé de 20 cm + enduit en plâtre sur deux faces	56	53
Bloc de béton cellulaire de 24 cm + enduit en plâtre sur deux faces	40	37
Fenêtre équipée d'un double vitrage 4 (12) 10	35	32





## Airborne Noises Insulation

- o Airborne noise insulation depends on :
  - Area of the wall between the 2 rooms : if the area is doubled, **+3dB**
  - If the area is divided by 2, - 3dB

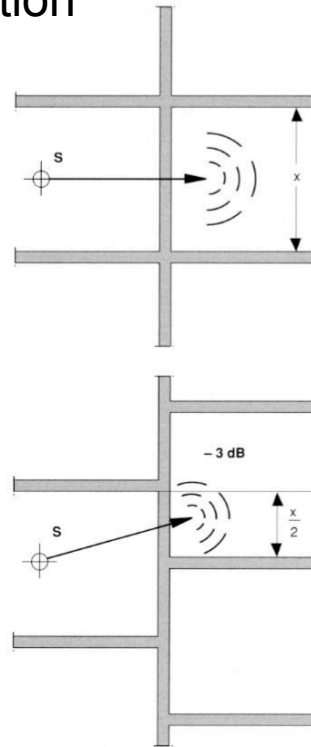

9



## Airborne Noises Insulation

- o Airborne noise insulation depends on :
  - if the volume is doubled : **-3dB**

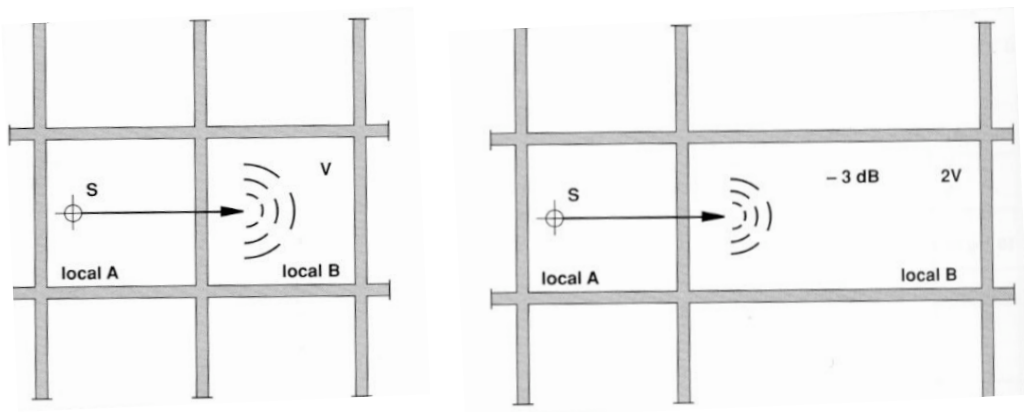

10



## Airborne Noises Insulation : Noises of reference

$R_W + C$  : Noise  
attenuation Index with  
pink noise (planes)

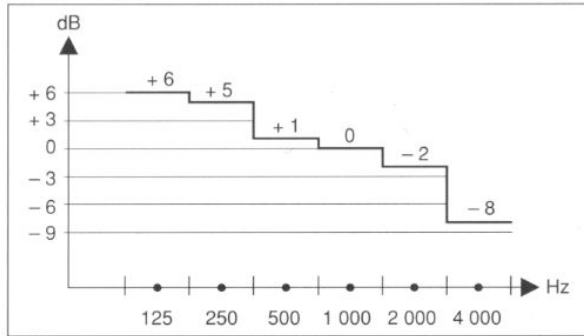

Fig. 1.4 – Bruit route représenté par bandes d'octave.

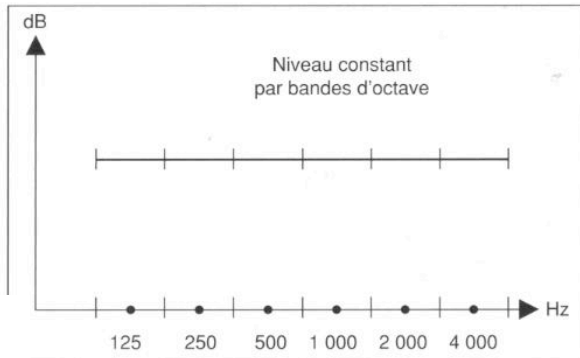

Fig. 1.3 – Bruit rose représenté par bandes d'octave.

$R_W + C_{tr}$  : Noise  
attenuation Index with  
road noise (cars and  
trains)

11



## Light walls

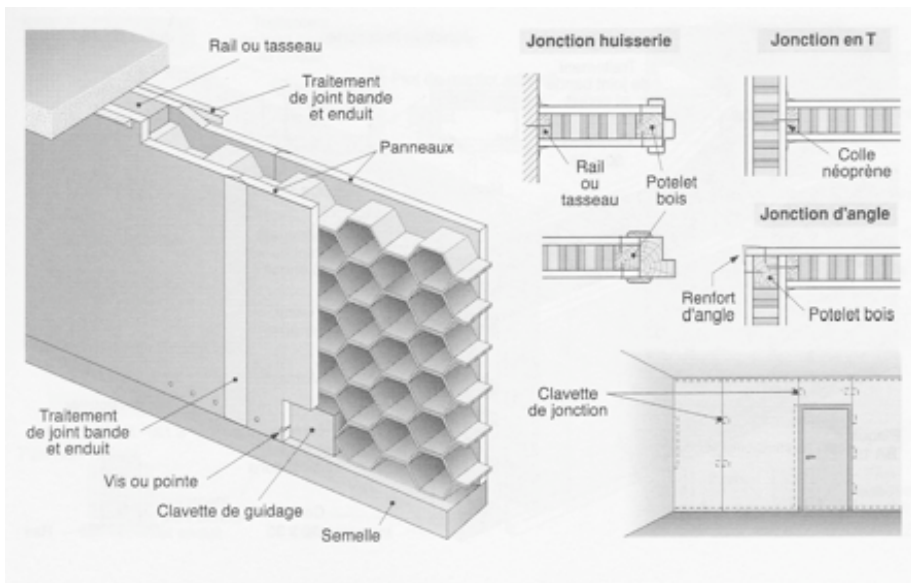
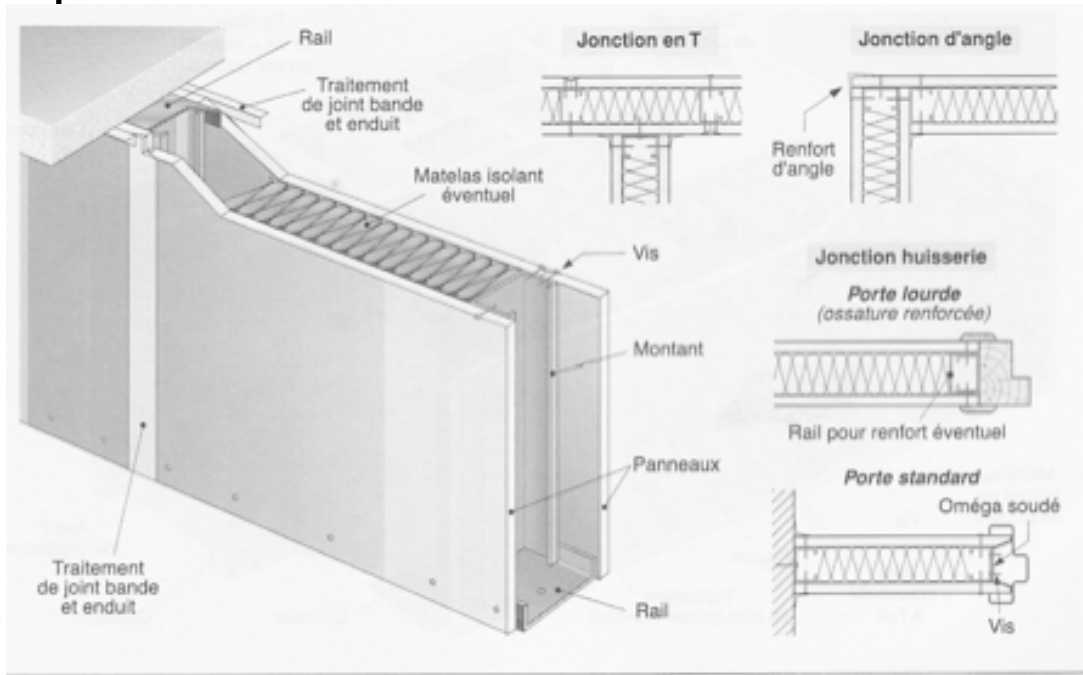

Figure 11.3 – Cloison non porteuse sur réseau alvéolaire (doc. Plâtres Lafarge).

12

# ● ● ● | Light walls



Source : La technique du bâtiment

Figure 11.4 – Cloison non porteuse sur ossature acier (doc. Plâtres Lafarge).

# ● ● ● | Light walls

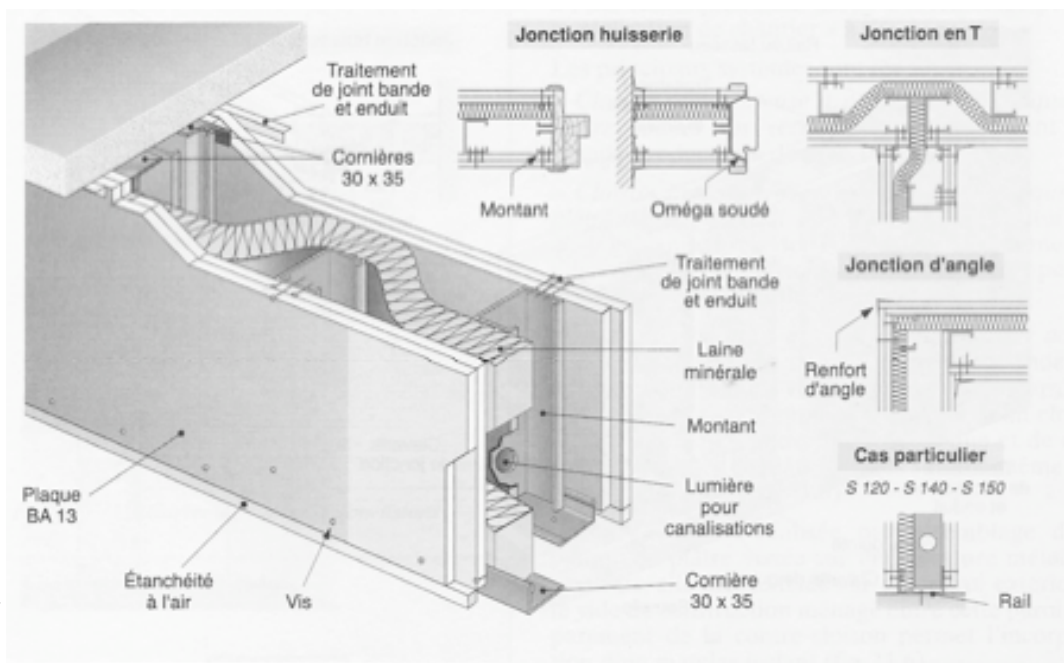

Source : La technique du bâtiment

Figure 11.5 – Cloison séparative à hautes performances acoustiques (doc. Plâtres Lafarge).

● ● ● | To damp out

○ Mass- spring- mass

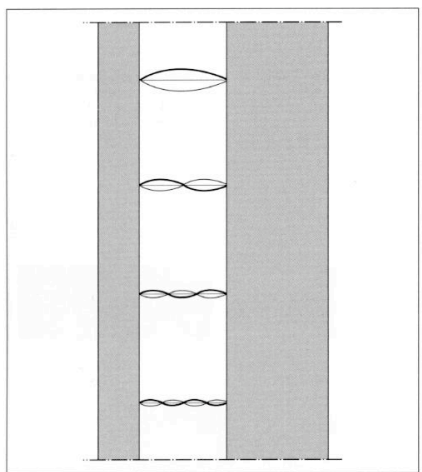
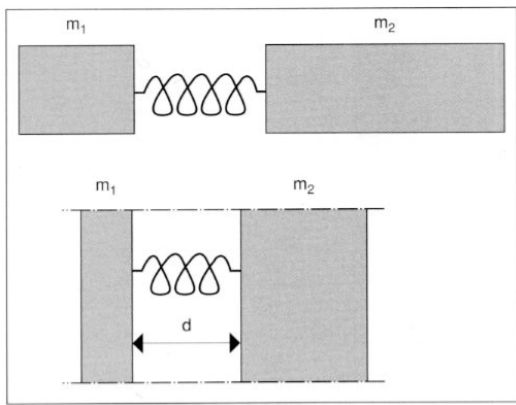
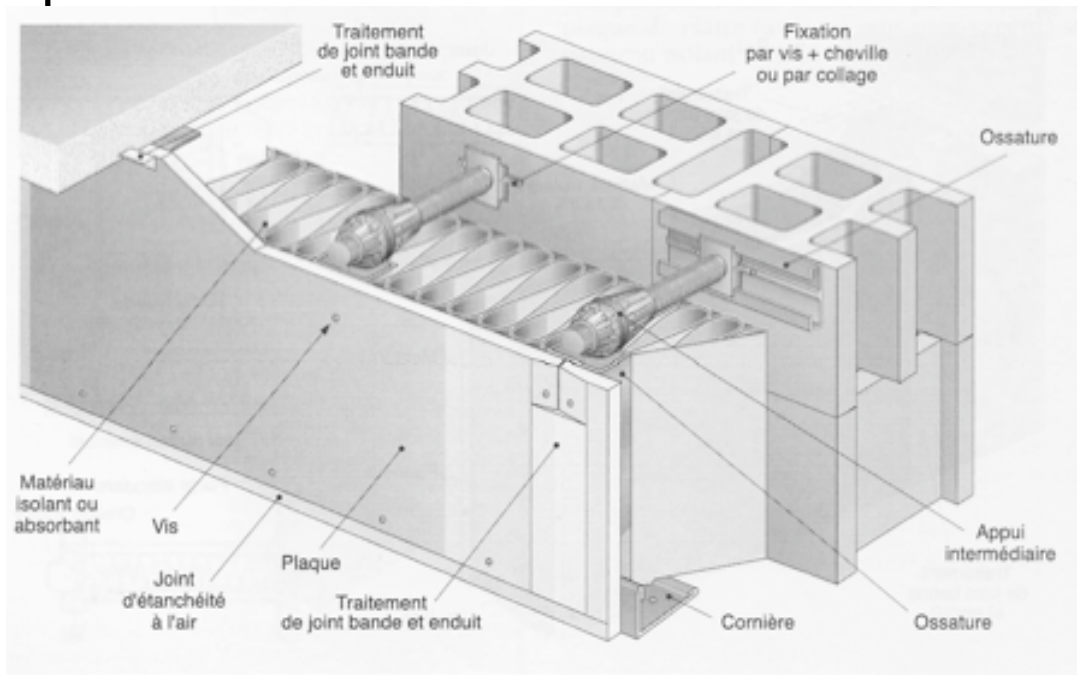

Fig. 1.8 – Formation d'ondes stationnaires.

● ● ● | Light walls



Source : La technique du bâtiment

Figure 11.6 – Contre-cloison (doc. Plâtres Lafarge).

# Light walls

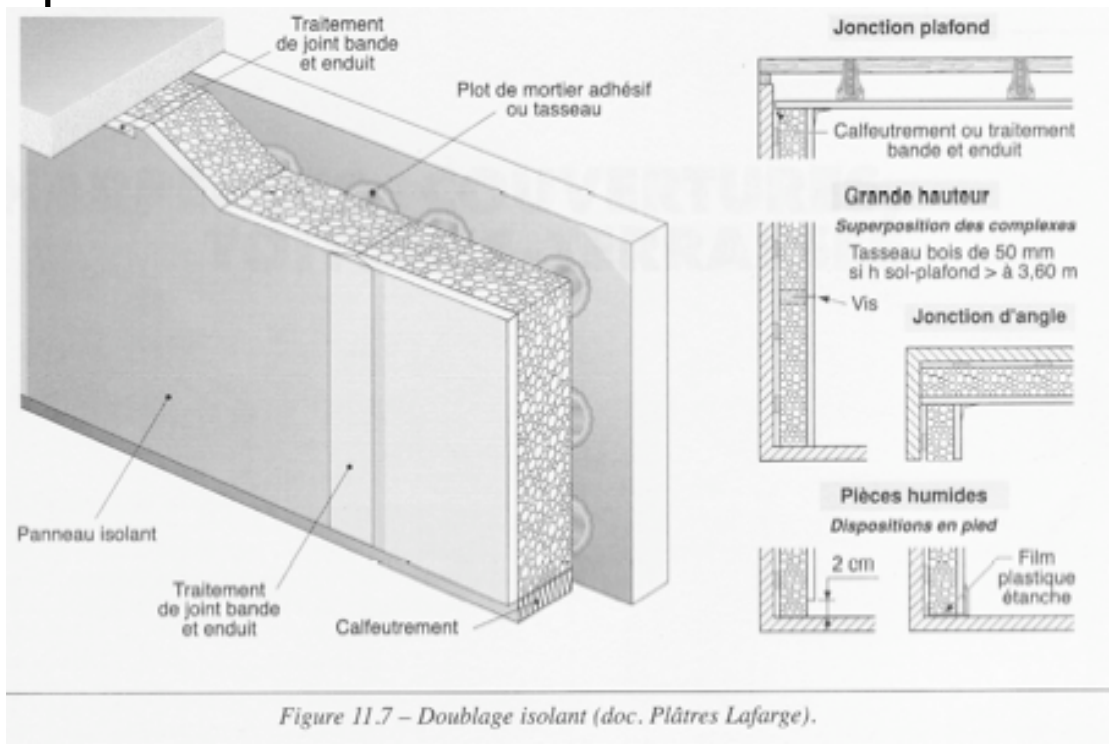

# Airborne Noises Insulation : Side transmissions

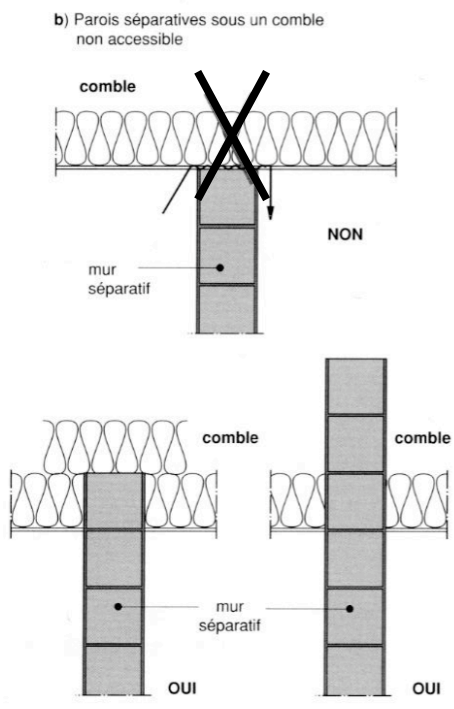

o The separative walls should never stop under a light ceiling

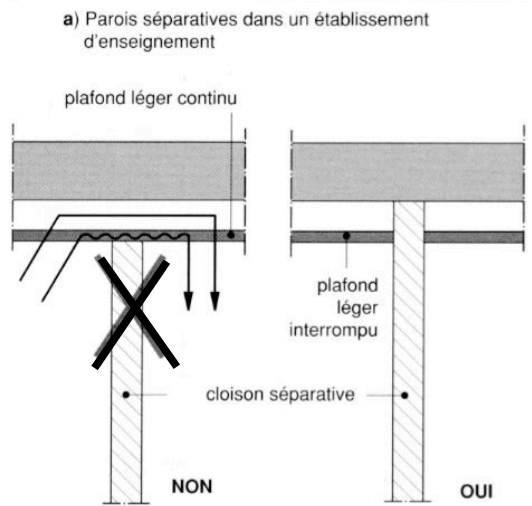



## Airborne Noises Insulation : Side transmissions

- o Junctions of separative walls with facade

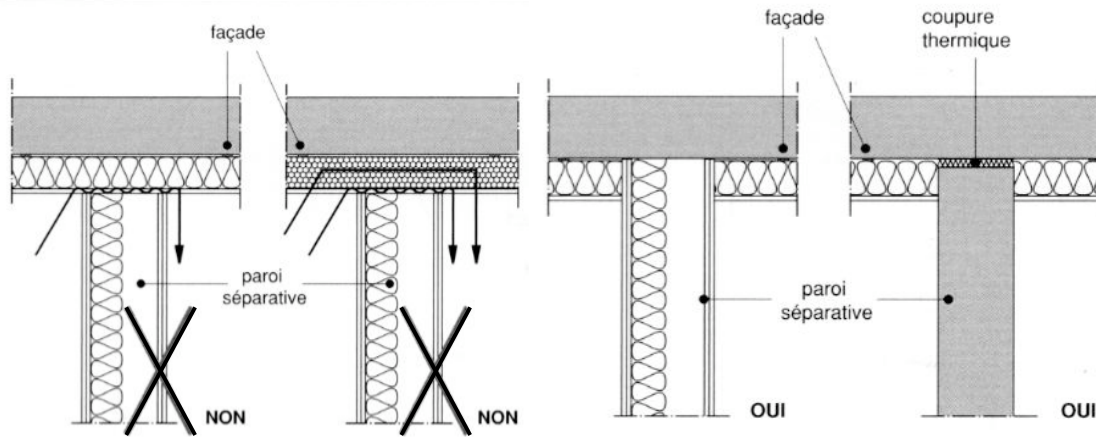

19



## Airborne Noises Insulation : Side transmissions

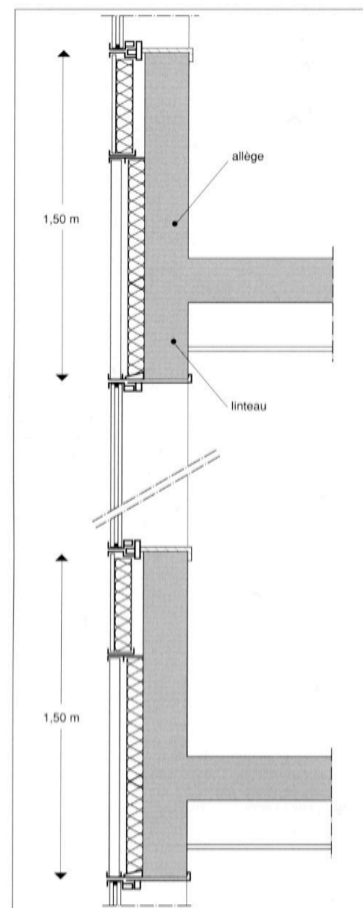
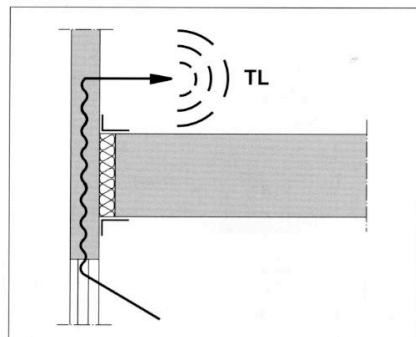



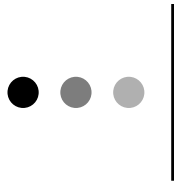

## Airborne Noises Insulation : parasitic transmissions

### o Conception and realisation mistakes

e) Canalisations de petit diamètre

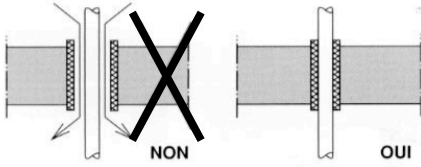

f) Canalisations de gros diamètre

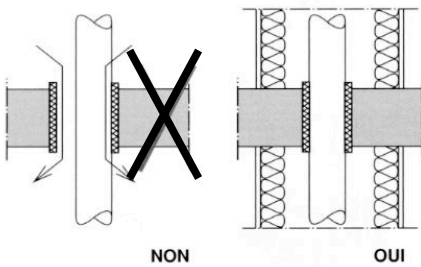

g) Murs séparatifs

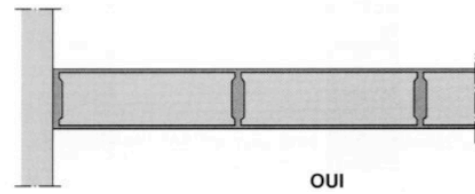
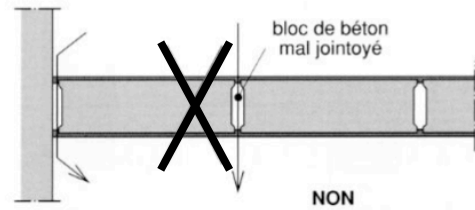
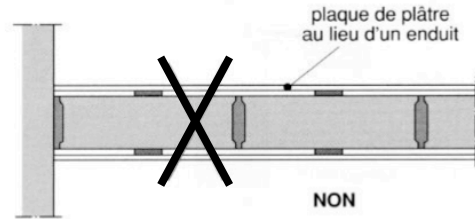

21

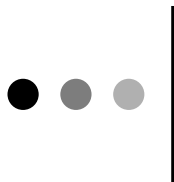

## Airborne Noises Insulation : parasitic transmissions

### o Conception and realisation mistakes

a) Trémies

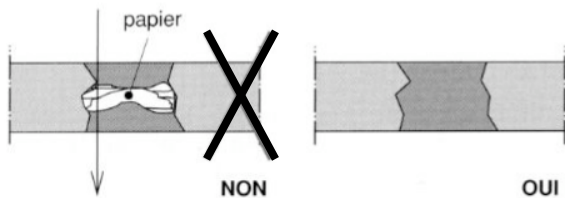

d) Jonctions porte/maçonnerie

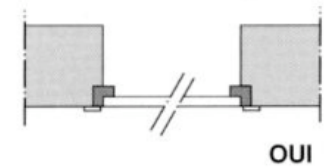
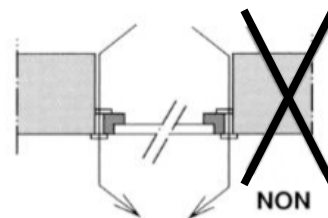

c) Coffres divers

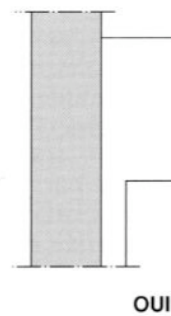
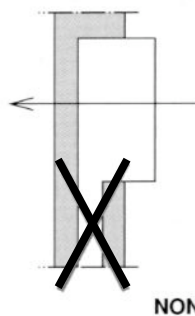

22

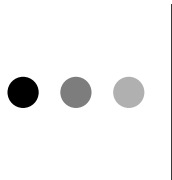

## Airborne Noises Insulation : parasitic transmissions

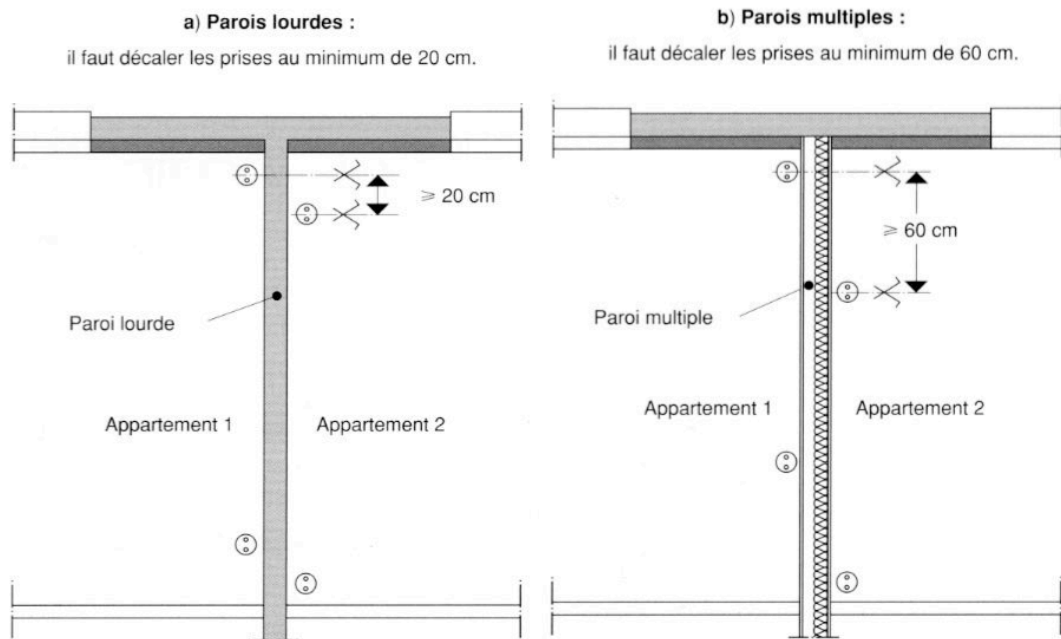

23

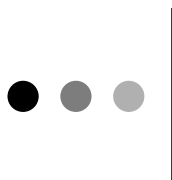

## Structure-borne noises

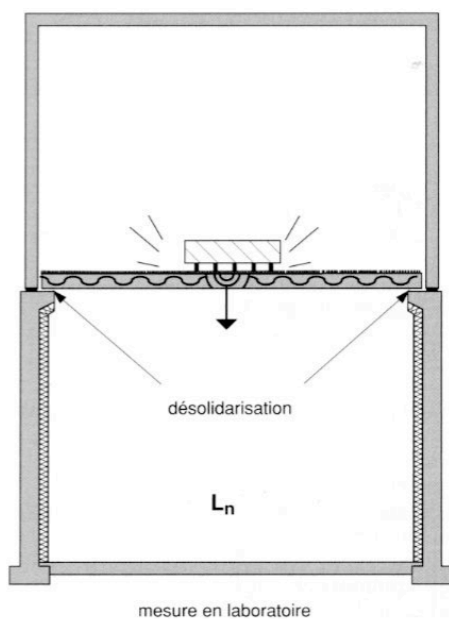

- The metallic and wooden structures are favourable to the damping of these noises (because of the discontinuity of the structure)
- Structure-borne noises can be put in 2 classes:
  - ✓ impact noise (primarily noise of steps)
  - ✓ equipment noises (elevator, mechanical ventilation, heating and cooling system, descent of fluids inside pipes)

24

# ● ● ● | Structure-borne noise

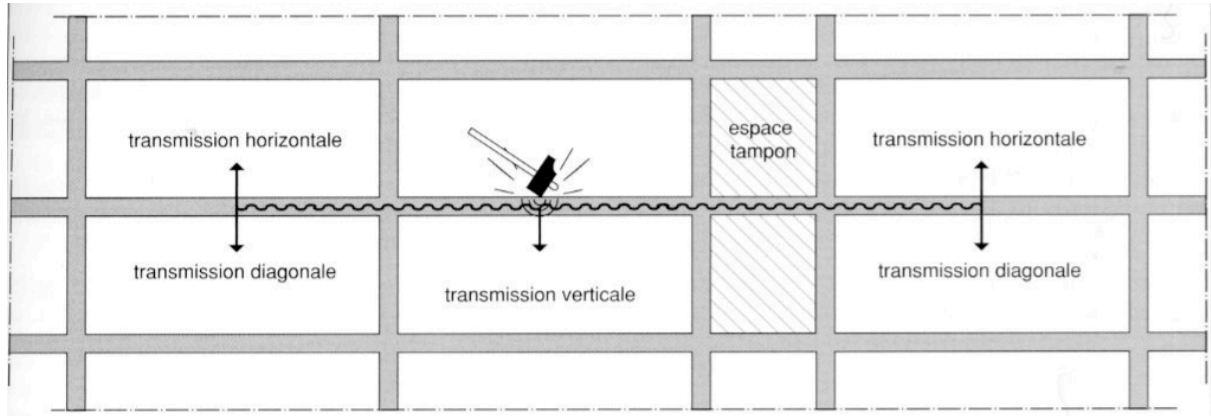

25

# ● ● ● | Structure-borne noise

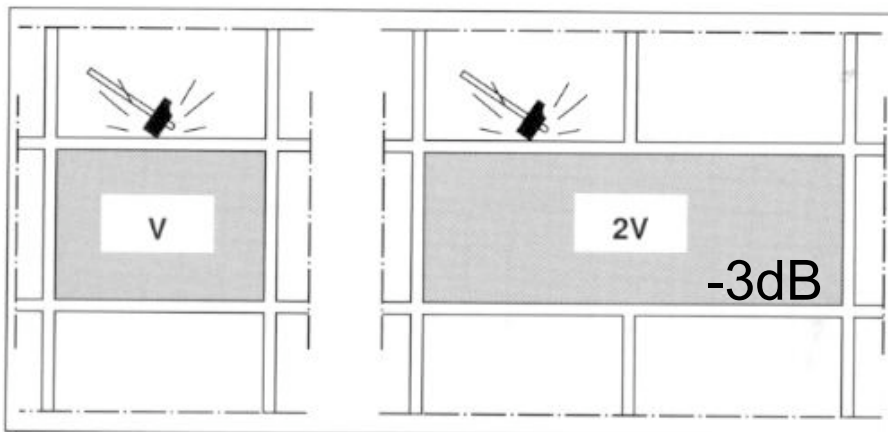

26

● ● ● | Structure-borne noise

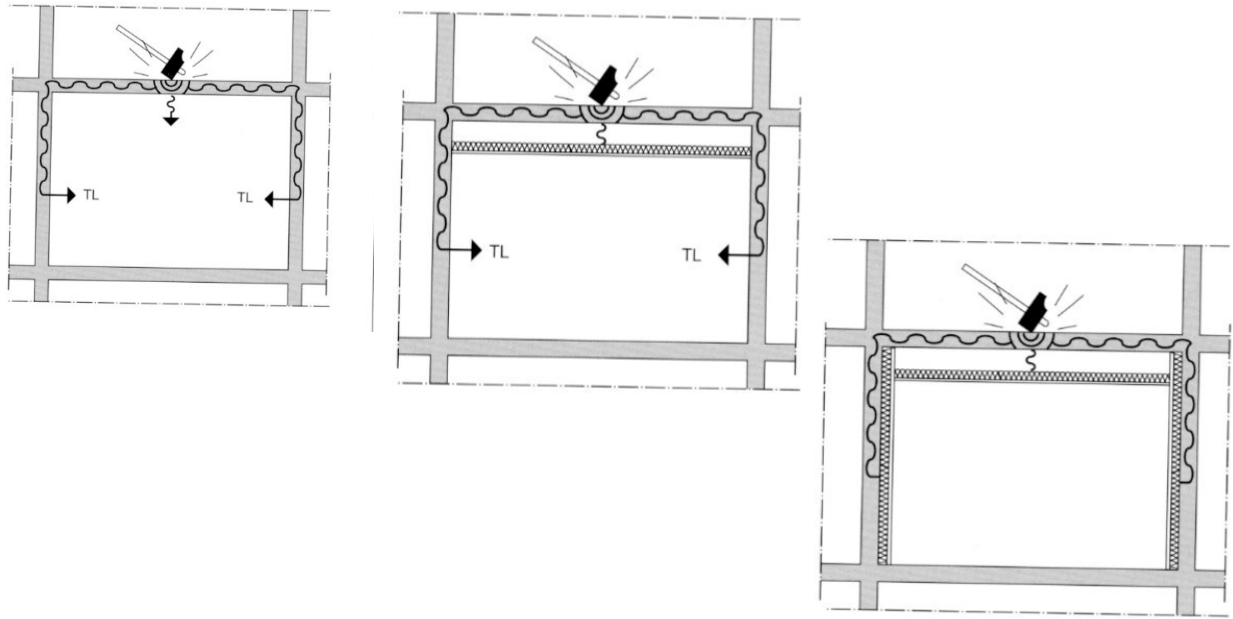

27

● ● ● |  $\Delta L_{n,w}$

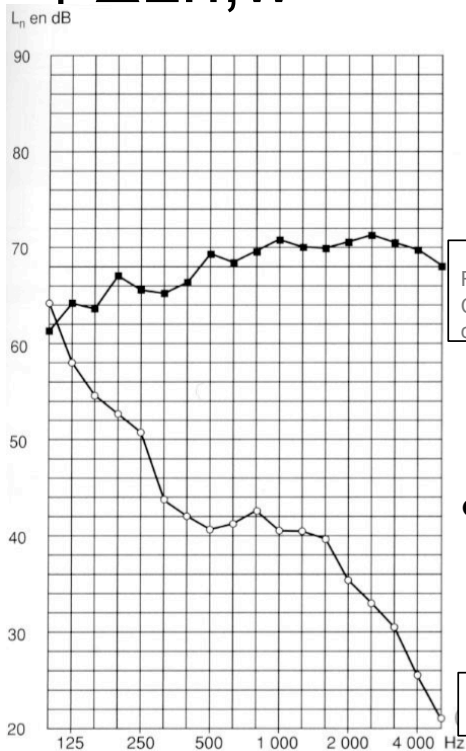

Reference floor:  
Concrete slab 14  
cm  $L_w = 77$ dB.

○ Standardised shock  
noise level  $\Delta L_{n,w} = 77 - 50$   
 $= 27$ dB

Floating slab 40 mm on rockwool  
40mm  $L_w = 50$ dB

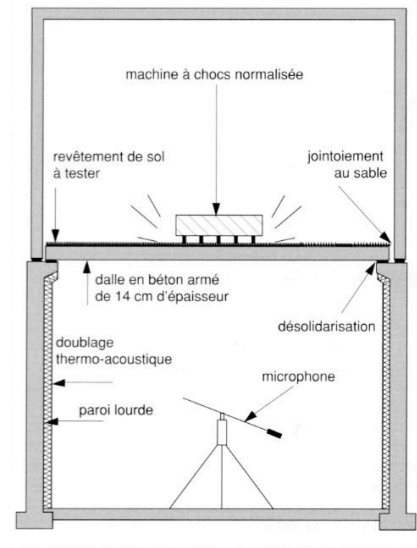
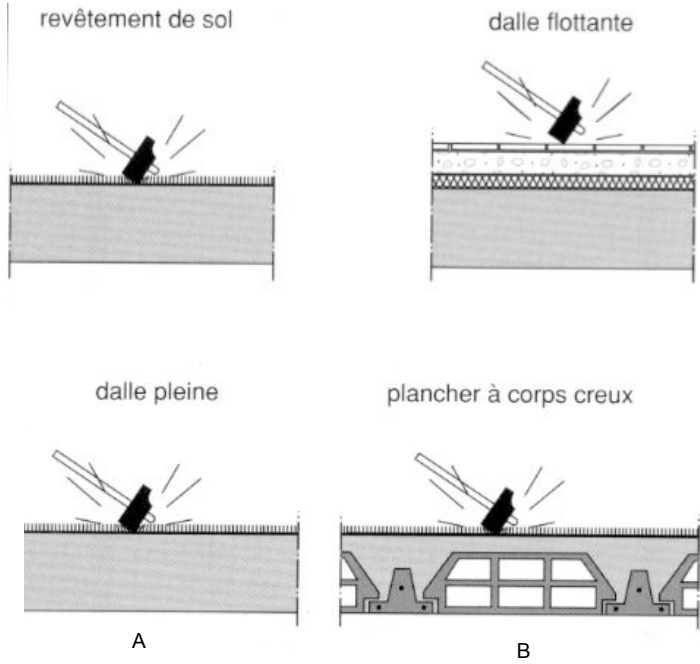

Fig. 4.2 – Chambre d'essais en laboratoire.

28

# ● ● ● | Structure-borne noise

○ Efficiency of the floor covering or efficiency of a slab is characterised by its noise reduction to impact noises,



○  $\Delta L_{WA} > \Delta L_{WB}$

# ● ● ● | Floating slab / facade

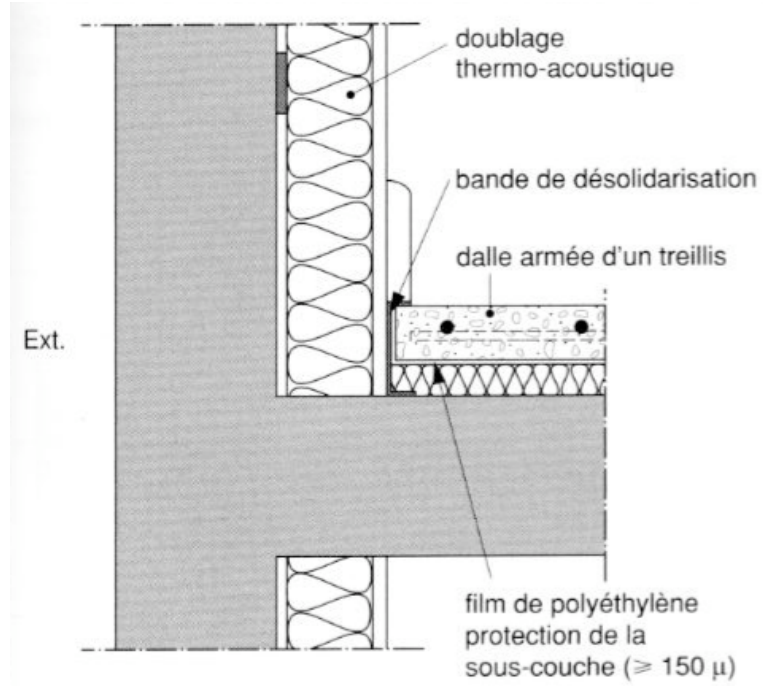

# ● ● ● | Floating slab / tiling

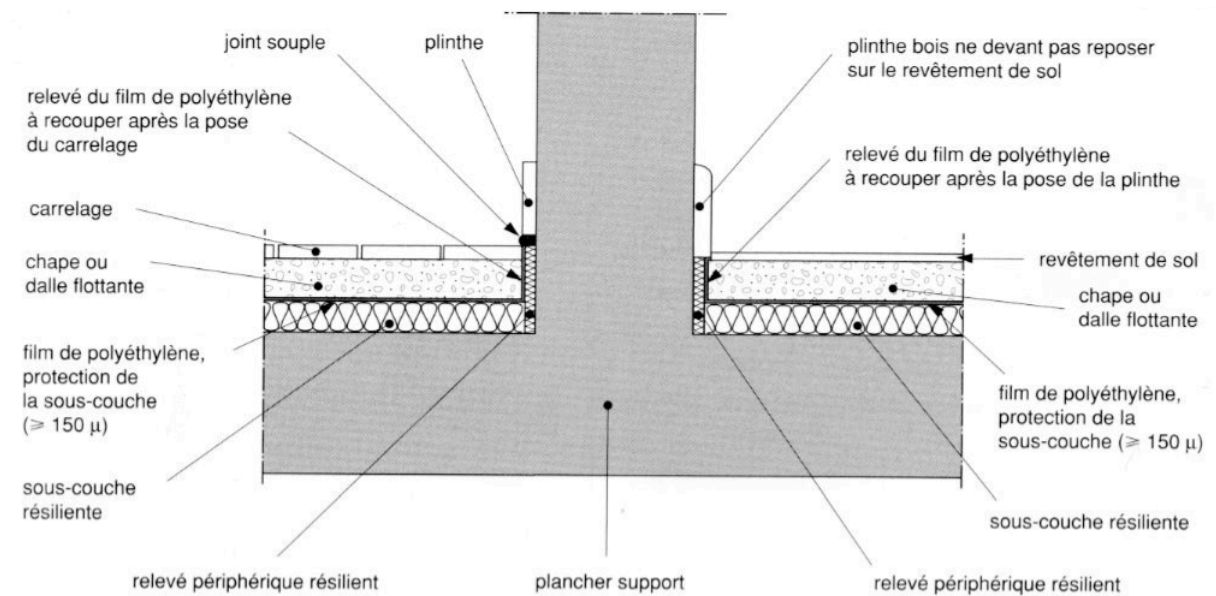

# ● ● ● | Floating slab execution : traps

a) Le plancher support doit être soigneusement nettoyé.



b) La sous-couche ne doit pas être interrompue.



c) Il faut éviter les liaisons rigides avec les murs.

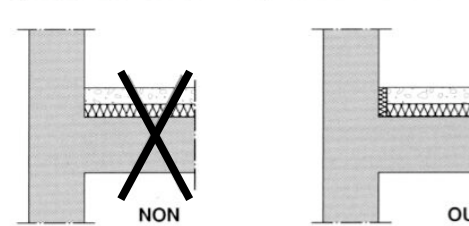

d) Il faut éviter les liaisons rigides avec les plinthes.

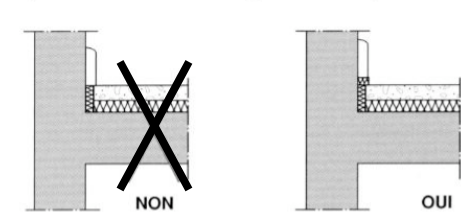

e) Il faut éviter de retourner la sous-couche sur le mur.

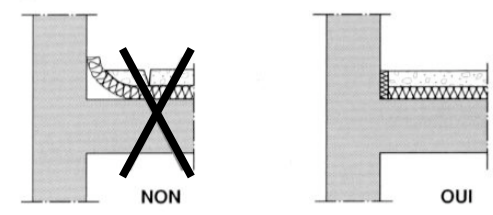





## Floating slab execution : traps

f) Il faut éviter de court-circuiter l'isolation par les radiateurs.

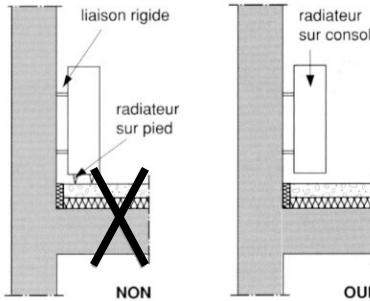

g) Il faut éviter de court-circuiter l'isolation par le passage d'une canalisation.

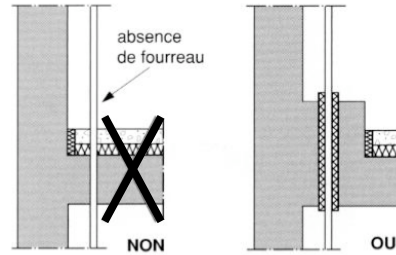

h) Il faut implanter les canalisations avec précaution.

Les canalisations doivent être, de préférence, noyées dans le béton.

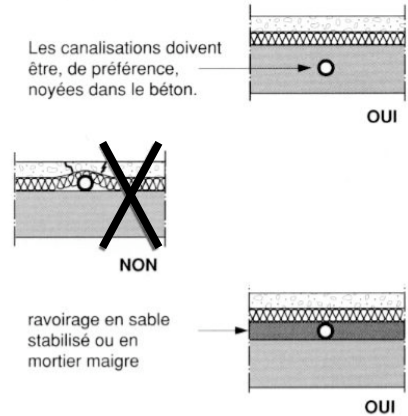

33



## Floating slab

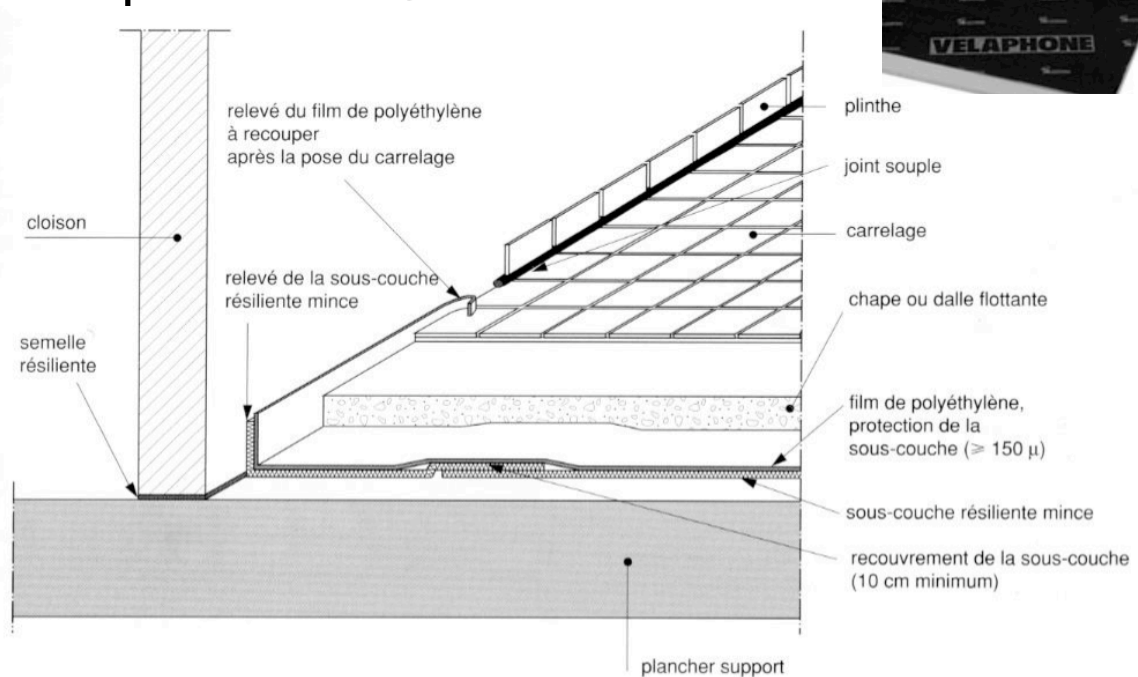

34



## Equipement noises

### o 2- Best strategies

- Choose quiet equipments ( $L_w$  lower as possible)
- to damp out the vibrations
- Disunite equipment from the main structure
- Choose the best place to put them (not behind bedrooms, do not fix them on light walls, etc ....)

35



## To damp out

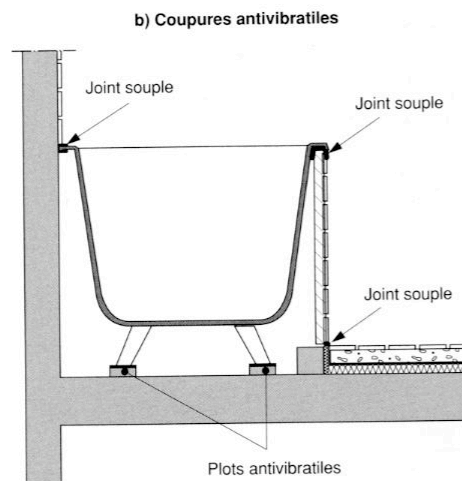
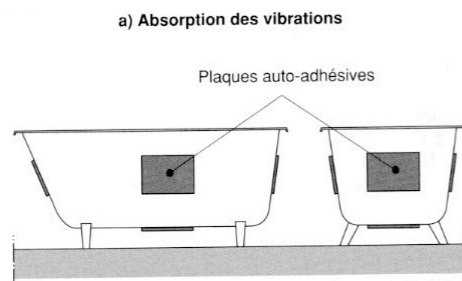
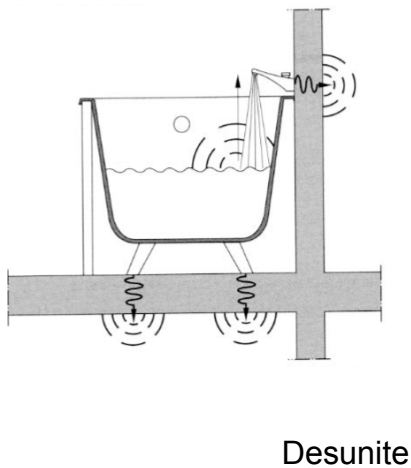

36

● ● ● | To damp out

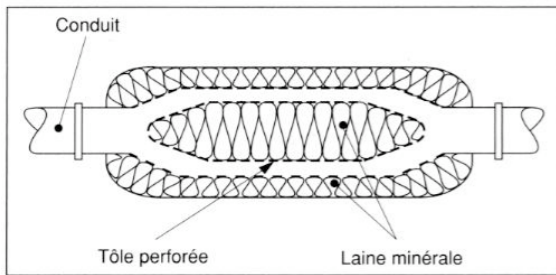

Fig. 8.6 – Silencieux passif.

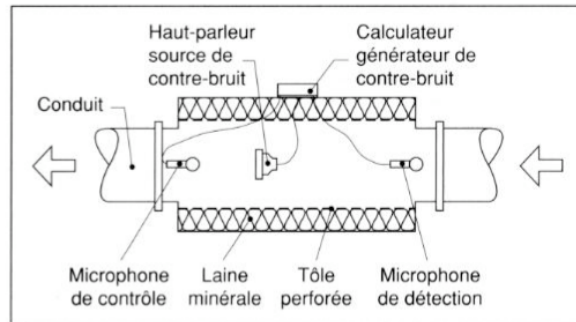

Fig. 8.7 – Silencieux actif.

● ● ● | Avoid sound generation

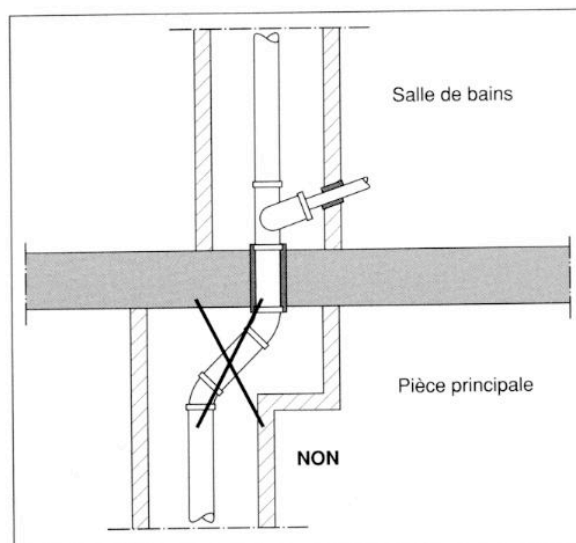
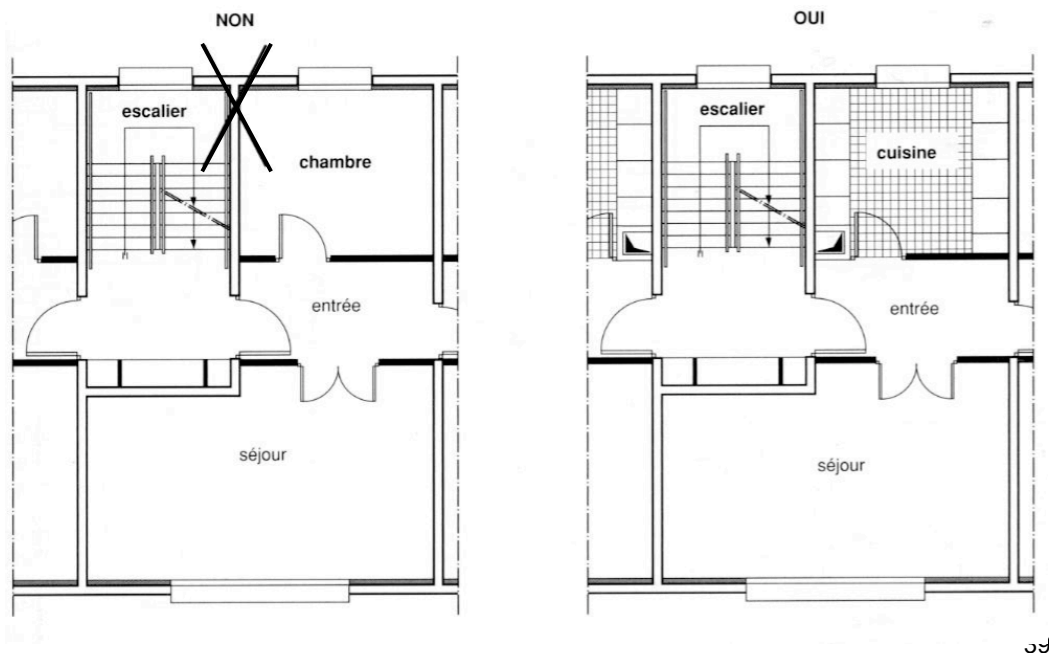
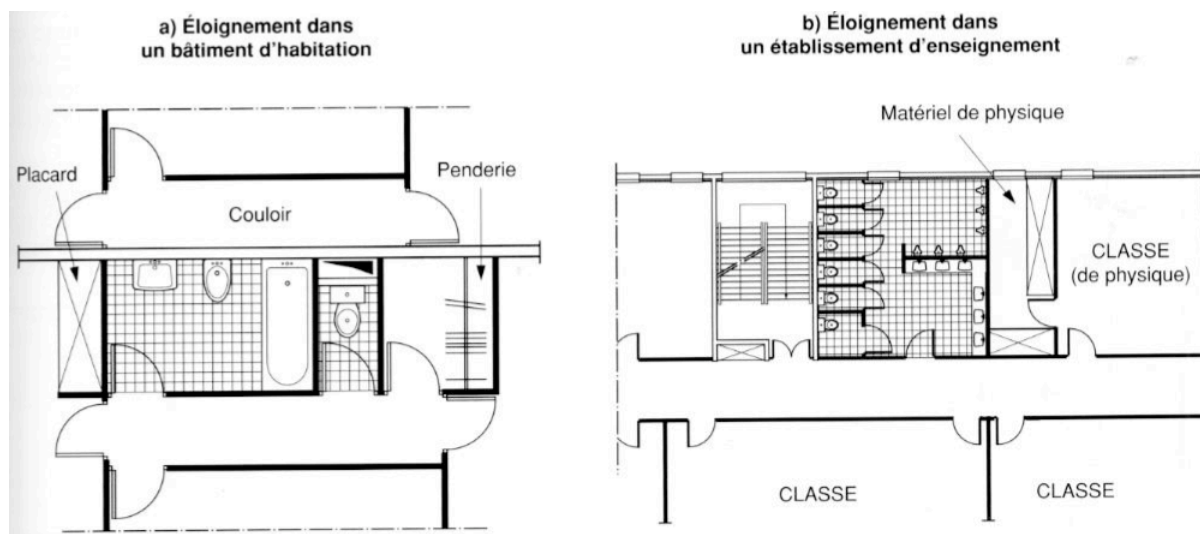

Fig. 6.6 – Éviter les coudes dans les pièces principales.

● ● ● | To move away the sensitive rooms



● ● ● | To move away the sensitive rooms



# ● ● ● | To move away the sensitive rooms

a) Éloignement du groupe de ventilation

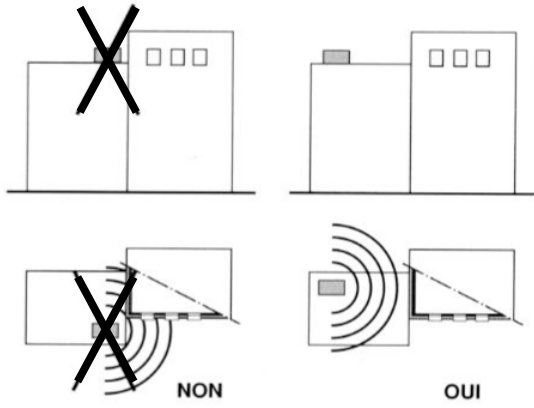

Le groupe doit être éloigné des ouvertures.

b) Protection autour du groupe de ventilation

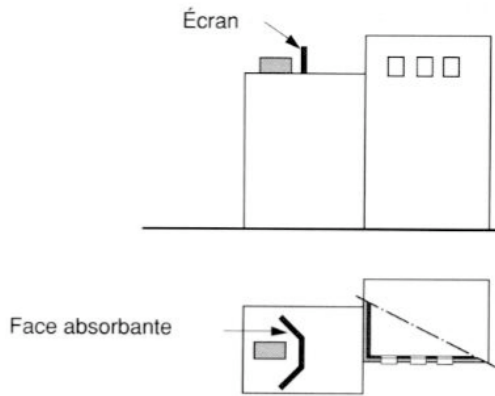

Le groupe peut être protégé par un écran.

41

# ● ● ● | To disunite walls

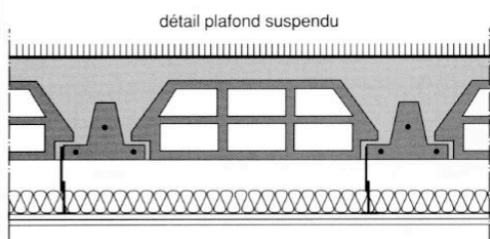
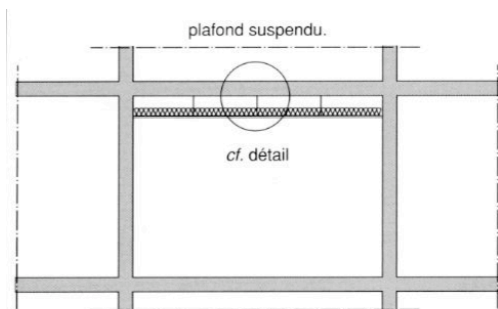

a) Coupure entre locaux.

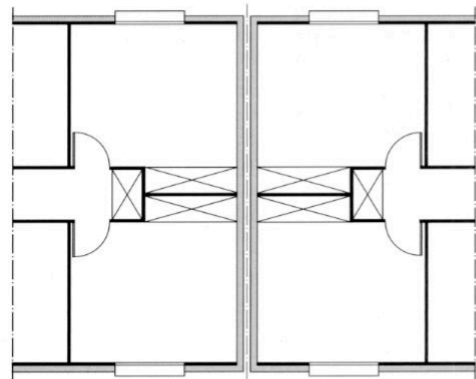

b) Système « boîte dans la boîte ».

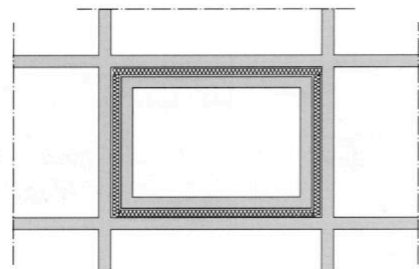

# To disunite walls

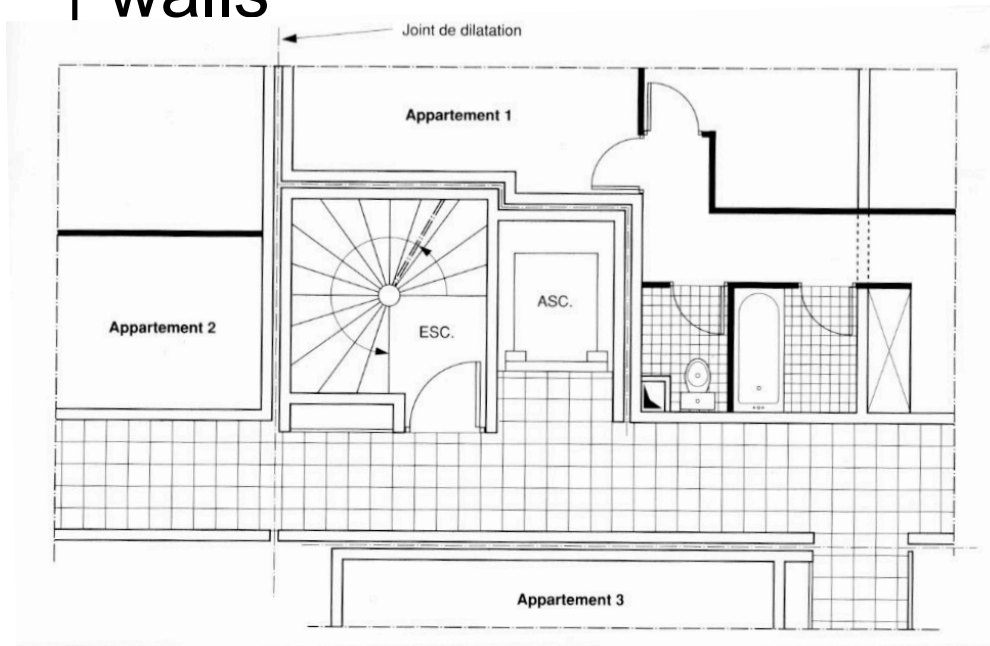
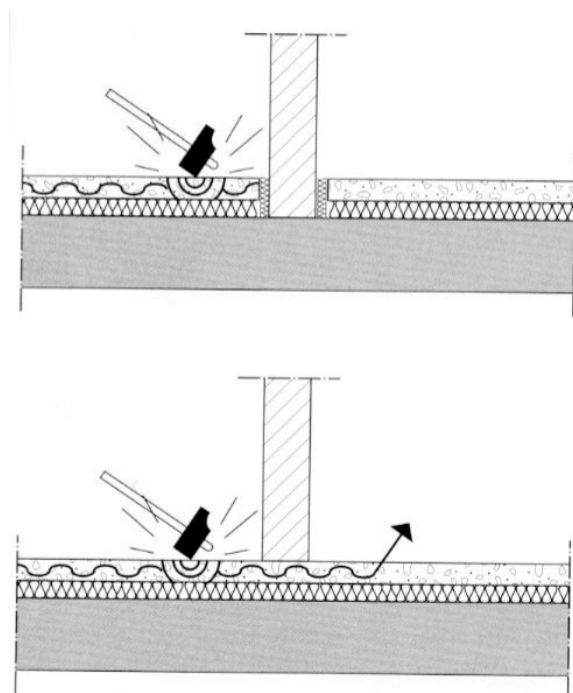
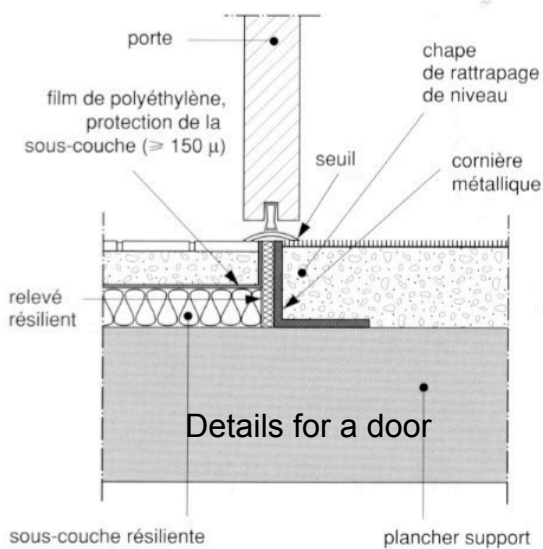

Fig. 10.7 – Joint de dilatation au niveau de l'escalier et de l'ascenseur d'un immeuble de logements au Mans. Architectes : L. Hamayon et Ph. Rousseau. 43

# To disunite floors

- o Be careful with floating slab





# ● ● ● | Desunite stairs

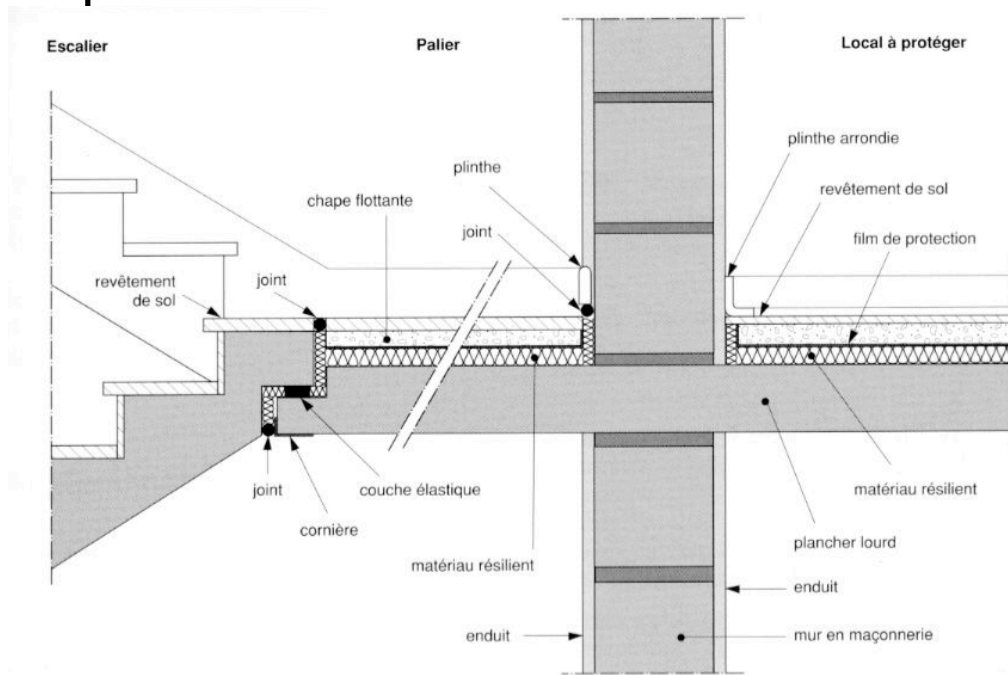

45

# ● ● ● | To disunite pipes

## ○ Sleeves of lines / pipes

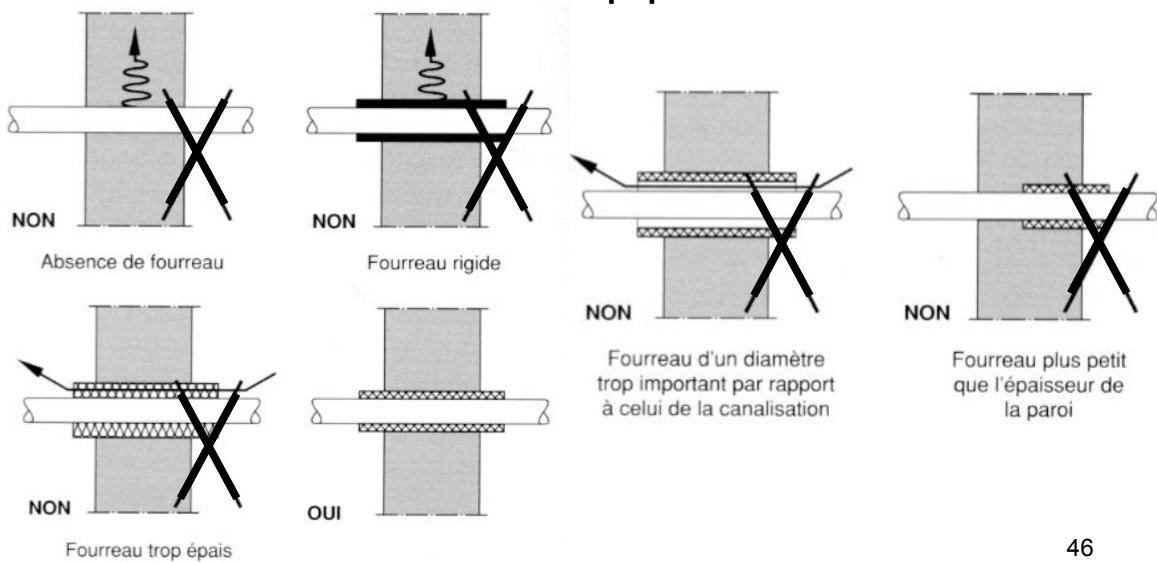

46

# ● ● ● | To disunite equipments

## ○ Antivibratory suspending rods and collars

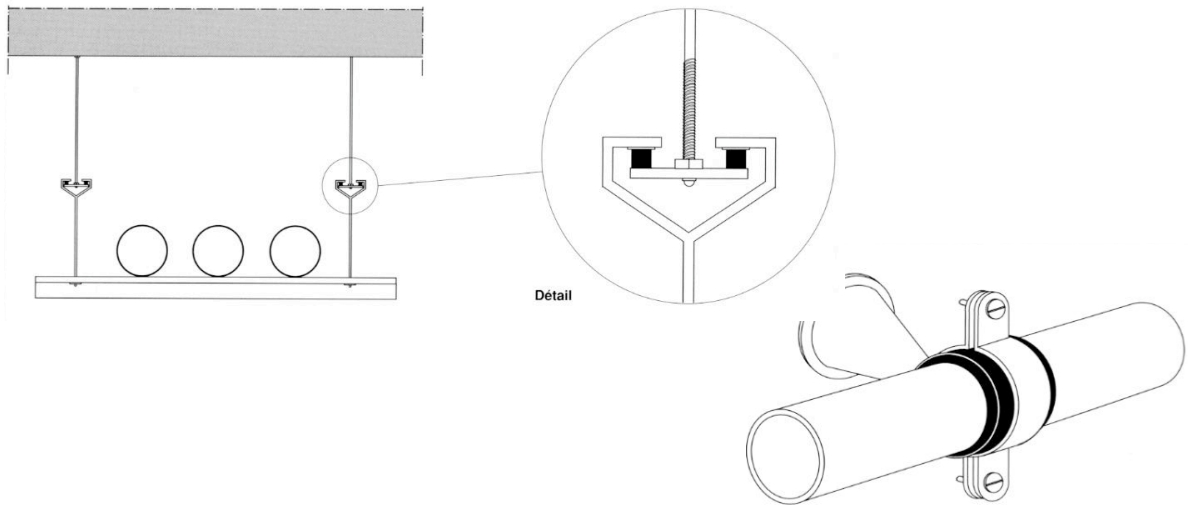

# ● ● ● | Hooding

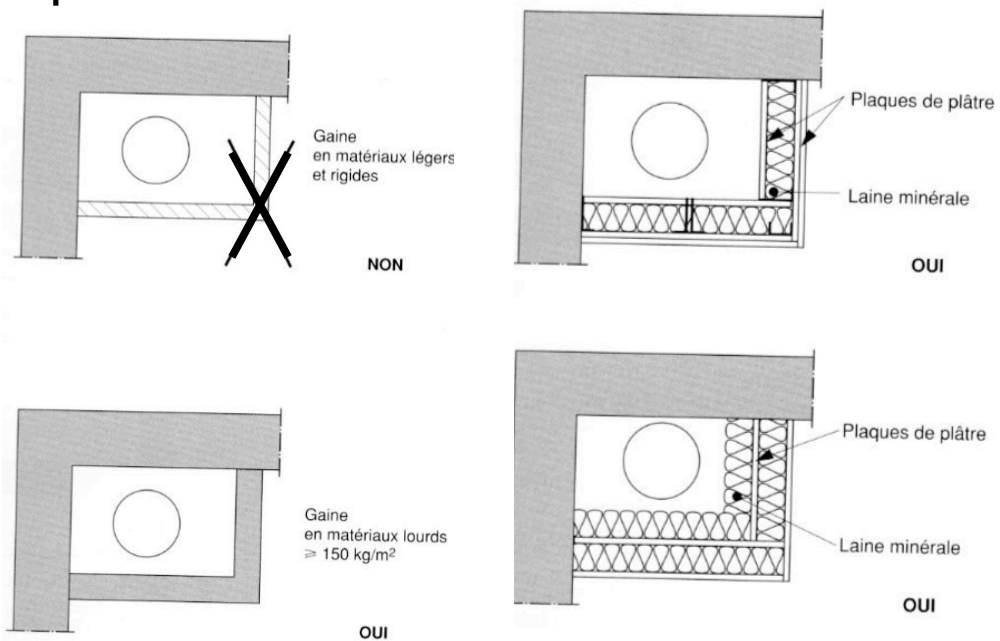

# ● ● ● | Double walls

- The box in a box principle

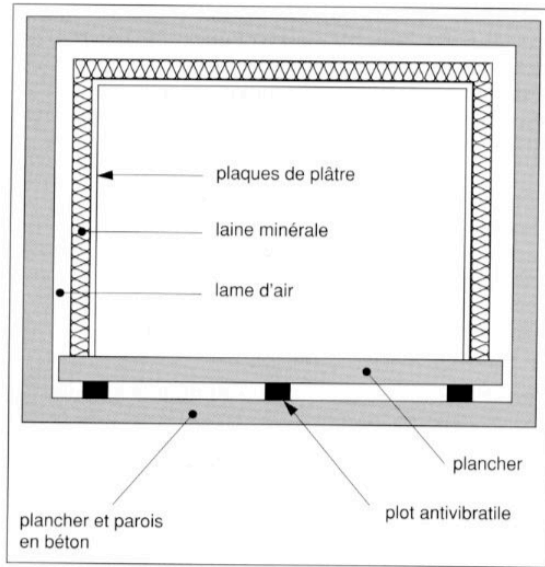

49

# ● ● ● | Acoustic insulation vs...

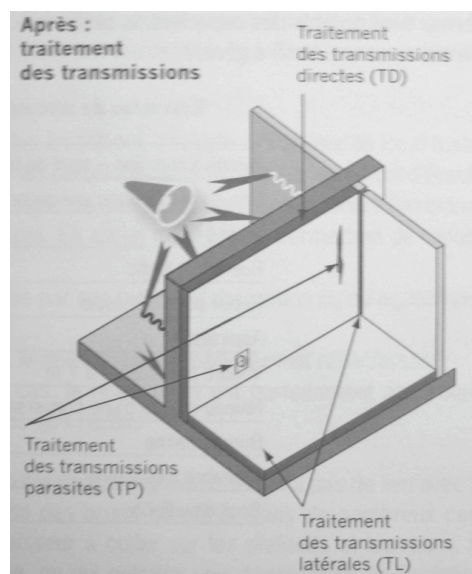
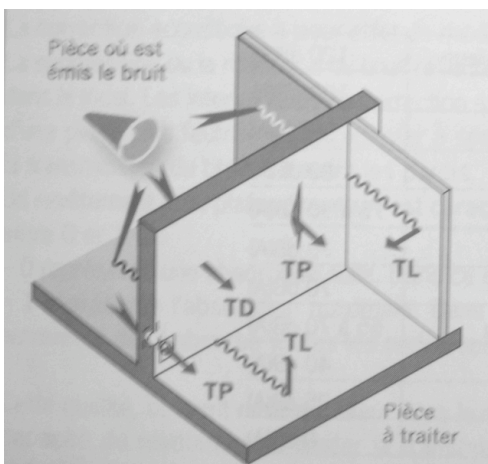

50



... rooms acoustics

