

# Space-Time Processing for Broadband Wireless Access

Naofal Al-Dhahir, Christina Fragouli, Anastasios Stamoulis, Waleed Younis, and Robert Calderbank  
AT&T Shannon Laboratory

## ABSTRACT

We present an overview of research activities on space-time coding for broadband wireless transmission performed at AT&T Shannon Laboratory over the past two years. The emphasis is on physical layer modem algorithms such as channel estimation, equalization, and interference cancellation. However, we also discuss the impact of space-time coding gains at the physical layer on throughput at or above the networking layer. Furthermore, we describe a flexible graphical user interface attached to our physical layer simulation engine in order to explore the performance of space-time codes under a variety of practical transmission scenarios. Simulation results for the EDGE cellular system and the 802.11 wireless LAN environment are presented.

## INTRODUCTION

As wireless communication systems look to make the transition from voice communication to interactive Internet data, achieving higher bit rates becomes both increasingly desirable and challenging. Space-time coding (STC) is a communications technique for wireless systems that employ multiple transmit antennas and single or multiple receive antennas. Information theory has been used to demonstrate that multiple antennas have the potential to dramatically increase achievable bit rates [1], thus converting wireless channels from narrow to wide data pipes. Space-time codes realize these gains by introducing temporal and spatial correlation into the signals transmitted from different antennas without increasing the total transmitted power or transmission bandwidth. There is in fact a diversity gain that results from multiple paths between base station and user terminal, and a coding gain that results from how symbols are correlated across transmit antennas. Significant increases in throughput are possible with only two antennas at the base station and one

or two antennas at the user terminal, and with simple receiver structures. The second antenna at the user terminal can be used to further increase system capacity through interference suppression.

STC enjoys several advantages that make it very attractive for high-rate wireless applications. First, it improves the downlink performance (which is the bottleneck in asymmetric applications such as Internet browsing and downloading) without the need for multiple receive antennas at the terminals (which are required to have low cost and a small form factor). Second, it elegantly combines spatial transmit diversity with channel coding (as shown in [2]) realizing a coding gain in addition to maximum diversity gain. Third, it does not require channel state information (CSI) at the transmitter, and by operating open loop, it eliminates the need for an expensive reverse link that may also be unreliable in case of rapid channel fading. Finally, it has been shown to be robust against nonideal operating conditions such as antenna correlation, channel estimation errors, and Doppler effects [3].

Initial STC research efforts focused on narrowband flat-fading channels [2–4]. **Successful implementation of STC over multi-user broadband frequency-selective channels requires the development of novel, practical, and high-performance signal processing algorithms for channel estimation, joint equalization/decoding, and interference suppression.** This task is quite challenging due to the long delay spread of broadband channels, which increases the number of channel parameters to be estimated and the number of trellis states in joint equalization/decoding, especially with multiple transmit antennas. This, in turn, places significant additional computational and power consumption loads on user terminals. On the other hand, development and implementation of such advanced algorithms for broadband wireless channels promises even more significant performance gains than those reported for narrowband

channels [2–4] due to availability of multipath (in addition to spatial) diversity gains that can be utilized.

**By virtue of their design, space-time-coded signals enjoy rich structure that can (and should!) be exploited to develop near optimum reduced complexity modem signal processing algorithms.** This article delineates this structure and uses several concrete examples to show how it can be utilized. In addition, we discuss the impact of these physical layer gains on the networking layer throughput. Finally, we describe a flexible graphical user interface we developed to simulate and explore the performance of space-time-coded systems.

## TWO SPACE-TIME CODING EXAMPLES

STCs come in two main flavors: trellis and block, as described next.

### SPACE-TIME TRELLIS CODES

The space-time trellis encoder maps the information bitstream into  $n_i$  streams of symbols (each drawn from a signal constellation of size  $2^b$  where  $b$  is the number of bits per symbol) that are transmitted simultaneously.<sup>1</sup> Design criteria for space-time trellis codes (STTCs) were provided in [2] that guarantee full spatial diversity and achieve additional coding gain on a flat quasi-static fading channel.

As an example, we consider the 8-state 8-phase shift keying (PSK) STTC for two transmit antennas for which the trellis description is given in [2, Fig. 7]. An equivalent and convenient implementation (for reasons that will shortly become clear) of the 8-state 8-PSK STTC encoder is shown in Fig. 1. This equivalent implementation makes the point that the 8-state 8-PSK STTC is identical to classical delay diversity transmission *except* that the delayed symbol from the second antenna is multiplied by  $-1$  if it is an odd symbol (1, 3, 5, or 7). This difference provides the additional coding gain.

### SPACE-TIME BLOCK CODES

The decoding complexity of STTC (measured by the number of trellis states at the decoder) increases *exponentially* as a function of the diversity level and transmission rate [2]. Alamouti [4] discovered a remarkable open-loop space-time block code (STBC) scheme for transmission with two antennas that has *linear* decoding complexity. According to this scheme, input symbols are grouped in pairs where symbols  $x_k$  and  $x_{k+1}$  are transmitted at time  $k$  from antennas 1 and 2, respectively. Then, at time  $k + 1$ , symbol  $-x_{k+1}^*$  is transmitted from antenna 1 and symbol  $x_k^*$  from antenna 2, where  $(\cdot)^*$  denotes the complex-conjugate transpose. This imposes an *orthogonal spatio-temporal structure* on the transmitted symbols that guarantees full (i.e., order 2) spatial diversity. Alamouti's STBC has been adopted in several wireless standards such as IS-136, wideband code-division multiple access (W-CDMA), and CDMA-2000.

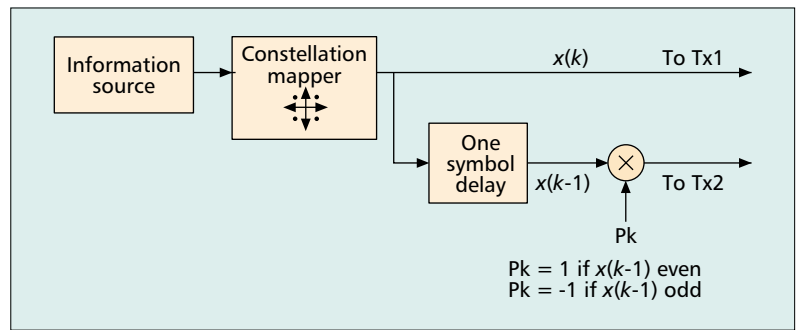

■ **Figure 1.** An encoder for 8-state 8-PSK STTC with two transmit antennas.

## SPACE-TIME CODING AND SIGNAL PROCESSING FOR BROADBAND

### WIRELESS MODEMS

In this section we start by describing our broadband frequency-selective channel model. Then we describe key signal processing functions in a broadband STC modem and show how STC structure can be exploited to enhance modem performance and reduce its complexity.

### THE BROADBAND CHANNEL MODEL

We consider space-time-coded transmission over frequency-selective channels where a single information stream is mapped by a space-time encoder to  $n_i$  streams. These streams are transmitted simultaneously from  $n_i$  antennas and received by  $n_o$  antennas. For simplicity, we focus on the case  $n_i = 2$  and  $n_o = 1$  in this article.

The channel impulse response (CIR) from the  $i$ th transmit antenna to the receive antenna is modeled as a finite impulse response (FIR) filter with memory  $v$  and is denoted by the vector  $\mathbf{h}_i$  or its corresponding D-transform  $h_i(D) \stackrel{\text{def}}{=} \sum_{k=0}^v \mathbf{h}_i(k)D^k$  for  $i = 1, 2$ . The symbol  $D$  denotes a unit delay and  $\mathbf{h}_i(k)$  is the  $k$ th element of  $\mathbf{h}_i$ . The two CIRs are assumed constant over the transmission block (quasi-static fading) and to vary independently from block to block. The transmitted symbols are assumed complex zero-mean and to be drawn from a standard signal constellation of size  $2^b$ . Our focus in this article will be on the 8-PSK constellation adopted in the EDGE<sup>2</sup> standard. The noise is additive white Gaussian and independent of the input.

### CHANNEL ESTIMATION

STC schemes run open loop, which makes them very attractive for wireless transmission. Nevertheless, CSI is still required at the receiver to perform key receiver signal processing functions such as joint equalization/decoding and interference cancellation. While *differential* STC schemes have been developed for broadband channels [5], they incur a significant performance penalty with respect to coherent techniques and hence are more suitable for rapidly time-varying channels. Since our focus here is on quasi-static fading, we only consider coherent STC processing where CSI is estimated at the receiver using a training sequence embedded in each transmission block.

<sup>1</sup> The total transmitted power is divided equally among the  $n_i$  transmit antennas.

<sup>2</sup> EDGE stands for enhanced data rates for global evolution.

For broadband transmissions, equalization is indispensable for mitigating inter-symbol interference. STC makes equalization more challenging because it generates multiple correlated signals that are transmitted simultaneously at equal power.

For single-transmit-antenna transmission, the training sequence is only required to have “good” (i.e., impulse-like) auto-correlation properties. However, for the  $n_i$  transmit-antenna scenarios, the  $n_i$  training sequences should, in addition, have “low” (ideally zero) cross-correlation. It can be shown that *perfect root of unity sequences* (PRUS) [6] have these ideal correlation properties. However, PRUS do not belong to standard signal constellations such as PSK. Additional challenges in channel estimation for multiple-transmit-antenna systems over the single-transmit-antenna case are the increased number of channel parameters to be estimated and the reduced transmit power (by a factor of  $n_i$ ) for each transmit antenna.

We proposed in [7] to encode a single training sequence by a space-time encoder to generate the  $n_i$  training sequences.<sup>3</sup> This approach is suboptimum since the  $n_i$  transmitted training sequences are cross-correlated by the space-time encoder, which imposes a constraint on the possible generated training sequences. However, it turns out that, with proper design, the performance loss from optimal PRUS training is negligible [7]. Furthermore, our approach reduces the training sequence search space from  $C^{n_i N_t}$  to  $C^{N_t}$  (assuming equal input and output alphabet size  $C$  and length  $-N_t$  training sequences), making exhaustive search more practical and thus facilitating the identification of good training sequences from standard signal constellations such as PSK. The search space can be further reduced by exploiting special characteristics of the particular STC. As an example, we examine the 8-state 8-PSK STTC of an earlier section and a modified version of the Alamouti STBC.

**STTC-Encoded Training Sequences** — Consider an STC with  $m$  binary memory elements and inputs/outputs from a constellation of size  $C$ . Embedding the STTC encoder structure in the CIR creates an equivalent single-input single-output (SISO) CIR of memory  $(m + v)$ , independent of the number of transmit antennas. Some special STTCs allow a nonlinear implementation with less than  $m$  (nonbinary) memory elements leading to an equivalent channel of memory smaller than  $(m + v)$ , which makes joint equalization/decoding possible without a prohibitive increase in complexity. As an example, consider the 8-state 8-PSK STTC for two transmit and one receive antennas of an earlier section. Embedding the space-time encoder of Fig. 1 in the two channels  $\mathbf{h}_1$  and  $\mathbf{h}_2$  results in an equivalent SISO *data-dependent* channel with memory  $(v + 1)$  whose D-transform is given by

$$h_{eq}^{STTC}(k, D) = h_1(D) + p_k D h_2(D), \quad (1)$$

where  $p_k = \pm 1$  is data-dependent (c.f. Fig. 1). For a given transmission block (over which the two channels  $\mathbf{h}_1$  and  $\mathbf{h}_2$  are constant), the input sequence determines the equivalent channel. By transmitting only even training symbols from the subconstellation  $C_e = \{0, 2, 4, 6\}$ ,  $p_k = +1$  and the equivalent channel is given by  $h_e(D) = h_1(D) + D h_2(D)$ . On the other hand, transmitting only odd training symbols from the subconstellation  $C_o = \{1, 3, 5, 7\}$  results in  $p_k = -1$  and the equivalent channel  $h_o(D) = h_1(D) - D h_2(D)$ . After

estimating  $h_e(D)$  and  $h_o(D)$ , we can compute

$$h_1(D) = \frac{h_e(D) + h_o(D)}{2},$$

$$h_2(D) = \frac{h_e(D) - h_o(D)}{2D}.$$

We propose to use a training sequence of the form  $\mathbf{s} = [\mathbf{s}_e \ \mathbf{s}_o]$  where  $\mathbf{s}_e$  has length  $N_t/2$  and takes values in the  $C_e$  subconstellation and so has length  $N_t/2$  and takes values in the  $C_o$  subconstellation. Note that if  $\mathbf{s}_e$  is a good sequence in terms of minimum mean square error (MMSE) for the estimation of  $h_e(D)$ , the sequence  $\mathbf{s}_o$  created as  $\mathbf{s}_o = a \mathbf{s}_e$  where  $a = \exp(i\pi k/4)$  and any  $k = 1, 3, 5, 7$  achieves the same MMSE for the estimation of  $h_o(D)$ . Thus, instead of searching over all possible  $8^{N_t}$  sequences  $\mathbf{s}$ , we can further restrict the search space to the  $4^{N_t/2}$  sequences  $\mathbf{s}_e$ . A reduced-size search can identify sequences  $\mathbf{s}_e$  and  $\mathbf{s}_o = a \mathbf{s}_e$  such that the channel estimation MMSE is achieved. We emphasize that similar reduced-complexity techniques can be developed for other STTCs by deriving their equivalent encoder models (as in Fig. 1).

**STBC-Encoded Training Sequences** — This section presents training schemes based on the STBC in [8], which is an extension of the code in [4] for frequency-selective channels. The encoder maps two consecutive input blocks  $\mathbf{s}_1$  and  $\mathbf{s}_2$  to the blocks  $[\mathbf{s}_1 \ -\tilde{\mathbf{s}}_2^*]$  and  $[\mathbf{s}_2 \ \tilde{\mathbf{s}}_1^*]$  to be transmitted from the two antennas. The operation denoted by  $(\tilde{\cdot})$  refers to time-reversing a sequence, that is, if  $\mathbf{s} = [s(0) \ s(1) \ \dots \ s(N_t - 1)]$ , then  $\tilde{\mathbf{s}} = [s(N_t - 1) \ \dots \ s(1) \ s(0)]$ . Assume that this STBC is applied to the training symbols and that the channels  $\mathbf{h}_1$  and  $\mathbf{h}_2$  to be estimated remain constant over two blocks. The received signals during the first and second blocks denoted by  $\mathbf{y}_1$  and  $\mathbf{y}_2$ , respectively, are given by

$$\begin{bmatrix} \mathbf{y}_1 \\ \mathbf{y}_2 \end{bmatrix} = \underbrace{\begin{bmatrix} \mathbf{S}_1 & \mathbf{S}_2 \\ -\tilde{\mathbf{S}}_2^* & \tilde{\mathbf{S}}_1^* \end{bmatrix}}_{\mathbf{S}} \begin{bmatrix} \mathbf{h}_1 \\ \mathbf{h}_2 \end{bmatrix} + \begin{bmatrix} \mathbf{z}_1 \\ \mathbf{z}_2 \end{bmatrix}, \quad (2)$$

where the matrices  $\mathbf{S}_i$  and  $\tilde{\mathbf{S}}_i$  (for  $i = 1, 2$ ) are convolution matrices constructed from  $\mathbf{s}_i$  and  $\tilde{\mathbf{s}}_i$ , respectively. The vectors  $\mathbf{z}_1$  and  $\mathbf{z}_2$  denote noise. The smallest channel estimation MMSE is achieved when the two training sequences are uncorrelated which is equivalent to requiring that the off-diagonal elements of the training symbols correlation matrix  $\mathbf{S}^* \mathbf{S}$  are equal to zero. It can be shown that two simple choices that satisfy this requirement are

- Choose a sequence  $\mathbf{s}_1$  symmetric about its center with impulse-like auto-correlation and set  $\mathbf{s}_2 = \mathbf{s}_1$ .
- Choose a sequence  $\mathbf{s}_1$  with impulse-like auto-correlation and set  $\mathbf{s}_2 = \tilde{\mathbf{s}}_1$ .

In summary, **the rich STC structure can be utilized to simplify training sequence design for multiple-antenna transmissions without sacrificing performance.** For STBC, decoupling of the two inputs due to the Alamouti orthogonal structure removes the requirement of low cross-correlation between the two training sequences. Similarly, the

<sup>3</sup> We assume, for simplicity, the same space-time encoder for the training and information symbols. However, they could be different in general.

8-state 8-PSK STTC structure can be exploited to significantly reduce the training sequence search space while restricting the training symbols to belong to a standard signal constellation.

### EQUALIZATION

For broadband transmissions, equalization is indispensable for mitigating *intersymbol interference*. STC makes equalization more challenging because it generates multiple *correlated* signals that are transmitted *simultaneously at equal power*. However, carefully designed joint equalization/decoding schemes can exploit this correlation to achieve significant performance gains. In this section we describe practical near-optimal joint equalization/decoding schemes for STTC and STBC.

#### Equalization of Space-Time Trellis Codes —

When implementing the 8-state 8-PSK STTC over frequency-selective channels, its rich structure can be exploited to reduce equalization/decoding complexity. This is achieved by performing trellis joint equalization and space-time decoding with  $8^{v+1}$  states on the equivalent channel given in Eq. 1. Without exploiting this structure, trellis equalization requires  $8^{2v}$  states and STTC decoding requires 8 states.

The M-BCJR algorithm is a reduced-complexity version of the famed BCJR algorithm [9] where at each trellis step, only the  $M$  active states associated with the highest metrics are retained. An improved version of the M-BCJR algorithm was proposed in [10] and applied to perform joint equalization and decoding of STTC. More specifically, it was shown in [10] that preceding the  $M$ -BCJR equalizer/decoder with a channel-shortening prefilter improves its performance, especially for small values of  $M$ . Even better performance is achieved when a different prefilter is used for the forward and backward recursions of the M-BCJR algorithm. The value of  $M$  and the number of prefilter taps can be jointly optimized to achieve the best performance-complexity tradeoffs.

Consider the typical urban (TU) EDGE channel. The overall CIR<sup>4</sup> length is effectively four symbol periods (i.e.,  $v = 3$ ). We assume two transmit antennas and one receive antenna. For the 8-state 8-PSK STTC, we show in Fig. 2 the performance of the prefiltered M-BCJR equalizer/decoder as a function of the number of active states  $M$ . Also shown in the figure as a benchmark is the BER of a full BCJR equalizer [9] with 4096 states.<sup>5</sup> It can be seen that negligible performance improvement is achieved by increasing  $M$  beyond 16. Note that equalizers used in cellular phones today have 8 or 16 states, hence, our proposed equalization algorithms fit inside the current digital signal processor. In summary, **exploiting STTC structure by embedding the STTC encoder in the channel allows us to perform near-optimum joint equalization/decoding at practical complexity levels.**

#### Equalization of Space-Time Block Codes —

To realize multipath (in addition to spatial) diversity gains for frequency-selective channels, the Alamouti STBC scheme described in an earlier section is implemented at a *block* level in either the time or frequency domain. Here, we

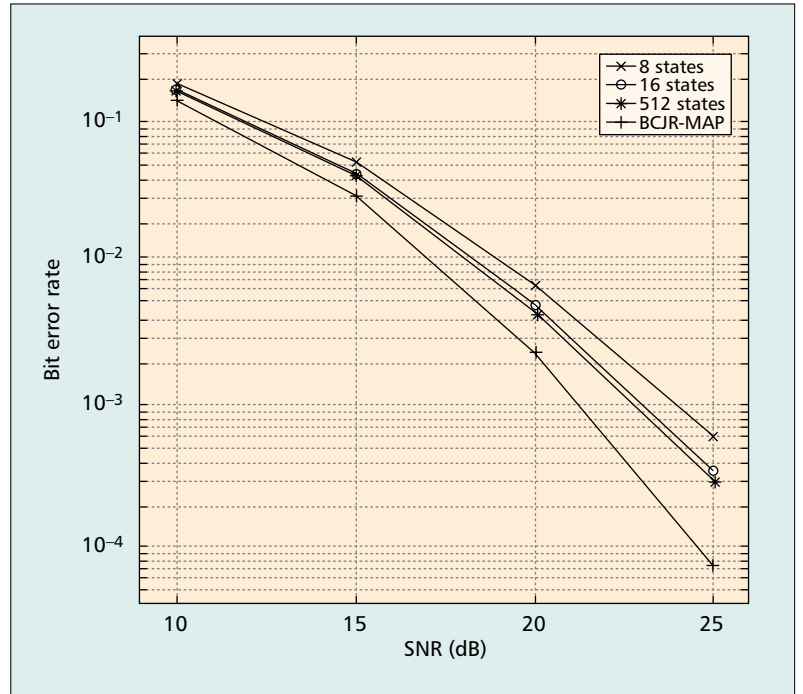

**Figure 2.** Bit error rate performance of 2-transmit 1-receive 8-state 8-PSK STTC with prefiltered  $M$ -BCJR equalizer/decoder as a function of  $M$  (the number of active states). The performance of a 4096-state full BCJR equalizer/decoder is shown as a benchmark.

consider one such scheme, namely, the single-carrier frequency-domain-equalized (SC FDE) STBC [11] because it achieves a favorable performance-complexity trade-off for broadband wireless channels. Being a frequency-domain scheme, the SC FDE has similar complexity to *orthogonal frequency-division multiplexing* (OFDM). However, being a single-carrier scheme, it avoids OFDM's shortcomings of high peak-to-average ratio and high sensitivity to frequency errors [12]. We start by describing the transmission scheme for SC FDE-STBC.

Denote the  $n$ th symbol of the  $k$ th transmitted block from antenna  $i$  by  $x_i^{(k)}(n)$ . At times  $k = 0, 2, 4, \dots$ , pairs of length  $-N$  blocks  $x_1^{(k)}(n)$  and  $x_2^{(k)}(n)$  (for  $0 \leq n \leq N-1$ ) are generated by an information source. Inspired by the Alamouti STBC [4], we propose the following transmit diversity scheme [11]:

$$\begin{aligned} x_1^{(k+1)}(n) &= -x_2^{*(k)}((-n)_N) \text{ and} \\ x_2^{(k+1)}(n) &= -x_1^{*(k)}((-n)_N) \end{aligned} \quad (4)$$

for  $n = 0, 1, \dots, N-1$  and  $k = 0, 2, 4, \dots$

where  $(\cdot)_N$  denotes the modulo- $N$  operation. In addition, a *cyclic prefix* (CP) of length  $v$  is added to each transmitted block to eliminate *interblock interference* and make all channel matrices *circulant*. Finally, the transmitted power from each antenna is half its value in the single-transmit case so that total transmitted power is fixed.

The SC FDE-STBC receiver block diagram is given in Fig. 3. After analog-to-digital (A/D) conversion, the CP part of each received block is discarded. The resulting length  $-N$  blocks are then processed in pairs where they are first transformed to the frequency domain using the fast

<sup>4</sup> Overall CIR is the convolution of the linearized Gaussian minimum shift keying transmit filter and the physical multipath channel.

<sup>5</sup> The equivalent SISO channel of the 8-state 8-PSK STTC has memory of  $v + 1 = 4$  (c.f. Eq.1). Hence, the number of states in a full BCJR equalizer is  $8^4 = 4096$ .



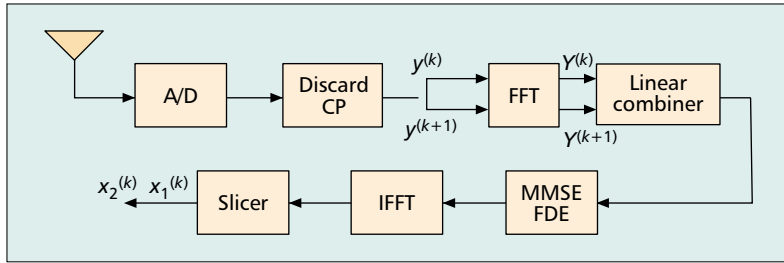

Figure 3. An FDE-STBC receiver block diagram.

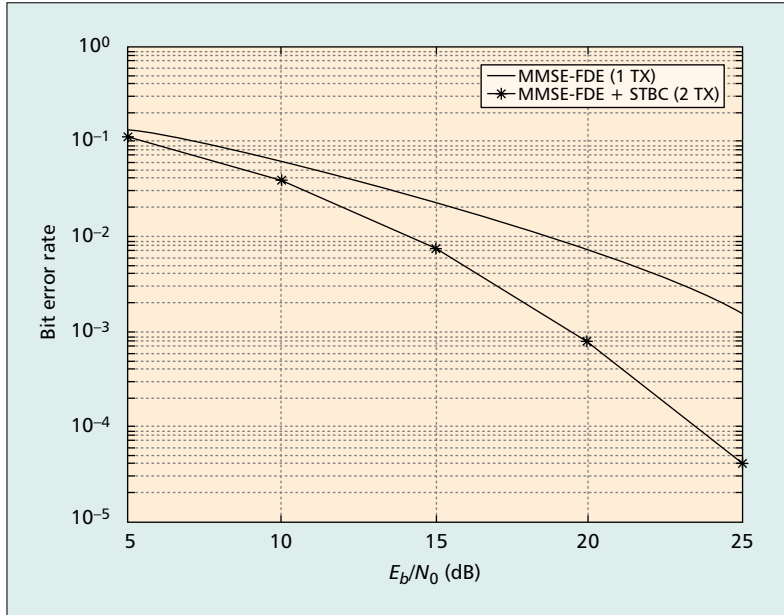

Figure 4. The bit error rate of MMSE-FDE w/ and w/o STBC for EDGE TU channel and  $N = 64$ .

Fourier transform (FFT), resulting in the two blocks

$$\underbrace{\begin{bmatrix} \mathbf{Y}^{(k)} \\ \mathbf{Y}^{*(k+1)} \end{bmatrix}}_{\mathbf{Y}} = \underbrace{\begin{bmatrix} \Lambda_1 & \Lambda_1 \\ \Lambda_2^* & -\Lambda_1^* \end{bmatrix}}_{\Lambda} \underbrace{\begin{bmatrix} \mathbf{X}_1^{(k)} \\ \mathbf{X}_2^{(k)} \end{bmatrix}}_{\mathbf{X}} + \underbrace{\begin{bmatrix} \mathbf{Z}_1^{(k)} \\ \mathbf{Z}^{*(k+1)} \end{bmatrix}}_{\mathbf{Z}}, \quad (4)$$

where  $\mathbf{X}_1^{(k)}$  and  $\mathbf{X}_2^{(k)}$  are the FFTs of the information blocks  $\mathbf{x}_1^{(k)}$  and  $\mathbf{x}_2^{(k)}$ , respectively, and  $\mathbf{Z}$  is the noise vector. Since circulant matrices are diagonalized by the FFT, *intercarrier interference* is eliminated and  $\Lambda_1$  and  $\Lambda_2$  are  $N \times N$  diagonal matrices containing the  $N$  FFT coefficients of  $\mathbf{h}_1$  and  $\mathbf{h}_2$ , respectively. To eliminate *interantenna interference*, the linear combiner  $\Lambda^*$  is applied to  $\mathbf{Y}$ . Due to the orthogonal Alamouti-like<sup>6</sup> structure of  $\Lambda$ , a second-order diversity gain is achieved. Then the two decoupled blocks at the output of the linear combiner are equalized separately using the MMSE FDE [12] which consists of  $N$  complex taps that mitigate *inter-symbol interference*. Finally, the SC MMSE-FDE output is transformed back to the time domain using the inverse FFT where decisions are made. Figure 4 shows the significant performance gains achieved by FDE-STBC over a single-transmit FDE for the EDGE TU channel by exploiting the special STBC structure.

<sup>6</sup> We call any  $2 \times 2$  complex orthogonal matrix of the form

$$\begin{bmatrix} c_1 & c_2 \\ \pm c_2^* & \mp c_1^* \end{bmatrix}$$

Alamouti-like.

<sup>7</sup> Better performance is achieved by an MMSE canceler that avoids noise enhancement [13].

We can double the number of STBC users (i.e., double system capacity) without additional radio spectrum resources by adding a second receive antenna at the base station and using interference cancellation techniques. These techniques exploit the rich STBC structure to reduce the number of receive antennas required (for effective joint equalization, decoding, and interference cancellation) compared to traditional antenna nulling techniques [13]. With two receive antennas and two STBC users (each equipped with two antennas), Eq. 4 generalizes to

$$\begin{bmatrix} \mathbf{Y}_1 \\ \mathbf{Y}_2 \end{bmatrix} = \begin{bmatrix} \Lambda_x & \Gamma_x \\ \Lambda_s & \Gamma_s \end{bmatrix} \begin{bmatrix} \mathbf{X} \\ \mathbf{S} \end{bmatrix} + \begin{bmatrix} \mathbf{Z}_1 \\ \mathbf{Z}_2 \end{bmatrix}, \quad (5)$$

where  $\mathbf{Y}_1$  and  $\mathbf{Y}_2$  are the processed signals from the first and second antennas while  $\mathbf{Z}_1$  and  $\mathbf{Z}_2$  are the corresponding noise vectors. The vector  $\mathbf{S}$  consists of two subvectors representing the size  $-N$  FFTs of the two information blocks transmitted from the interfering user's first and second antennas. The two STBC users can be decoupled by applying the following linear zero-forcing<sup>7</sup> interference canceler

$$\begin{bmatrix} \mathbf{R}_1 \\ \mathbf{R}_2 \end{bmatrix} \stackrel{\text{def}}{=} \begin{bmatrix} \mathbf{I} & -\Gamma_x \Gamma_s^{-1} \\ -\Lambda_s \Lambda_x^{-1} & \mathbf{I} \end{bmatrix} \begin{bmatrix} \mathbf{Y}_1 \\ \mathbf{Y}_2 \end{bmatrix} = \begin{bmatrix} \tilde{\Lambda}_x & \mathbf{0} \\ \mathbf{0} & \tilde{\Gamma}_s \end{bmatrix} \begin{bmatrix} \mathbf{X} \\ \mathbf{S} \end{bmatrix} + \begin{bmatrix} \tilde{\mathbf{Z}}_1 \\ \tilde{\mathbf{Z}}_2 \end{bmatrix}, \quad (6)$$

where  $(\cdot)^{-1}$  denotes the inverse,  $\tilde{\Lambda}_x \stackrel{\text{def}}{=} \Lambda_x - \Gamma_x \Gamma_s^{-1} \Lambda_s$  and  $\tilde{\Gamma}_s \stackrel{\text{def}}{=} \Gamma_s - \Lambda_s \Lambda_x^{-1} \Gamma_x$ . The critical observation to make here is that *both  $\tilde{\Lambda}_x$  and  $\tilde{\Gamma}_s$  are orthogonal Alamouti-like matrices*. Therefore, decoding proceeds as in the single-user case and the full diversity gain is guaranteed for both users.

## IMPACT ON NETWORKING THROUGHPUT

Up to this point, we have focused on how STBC improve BER at the physical layer (PHY). Now we switch gears and shed light on how STBC can be viewed as a building block toward faster, more reliable wireless local area networks (WLANs). In order to justify the inclusion of STBC as an indispensable component in a high-data-rate architecture, we have conducted a comprehensive across-the-network-layers study of the STBC impact on 802.11 networks. We emphasize that network performance, as perceived by a mobile wireless application, is determined to a significant degree by a complex interaction between PHY, link layer, medium access control (MAC), and TCP. Our study encompasses the aforementioned layers and illustrates that **although STBC are a PHY technique, they have a measurable impact at both the link and TCP layers. Essentially, STBC increase link layer throughput and present to TCP a "smoother" channel, thereby improving the overall network performance.**

We highlight some of our findings [14]:

¶ In 802.11a networks, we have quantified through simulations the improvements at the

PHY due to STBC. Although not a surprising result, the important practical ramification is that STBC modify the signal-to-noise ratio (SNR) region under which a particular transmission mode should be chosen. Hence, even under adverse channel conditions it is possible to send data packets at a higher-rate transmission mode.

¶The poor performance of TCP over wireless links is well documented [15]. STBC present to TCP a “smoother” channel because they modify the statistics of the effective wireless channel (e.g., STBC transform a Rayleigh fading channel to one with a chi-square distribution that has a “smoother” tail). Hence, from an application point of view (such as that of a Web browser), the inclusion of STBC at the PHY translates to impressive bandwidth improvements: not only does the application see a wider data pipe, but the wider pipe is available for longer periods of time.

¶In a multiple access environment, STBC improve the overall throughput in the network and reduce traffic delay variations. In a lightly loaded environment, STBC increase the link-layer/TCP throughput of individual transmitting pairs; consequently, the overall network throughput is increased. Quite remarkably, even in heavily loaded scenarios (where packet collisions are known to be the performance limiting factor), STBC improve performance [14].

Figure 5 depicts the aggregate throughput in a 802.11a network where five active TCP connections contend for the channel using the distributed coordination function (DCF) of 802.11 (we produced this figure by feeding the ns simulator with the traces of our PHY simulations). It is evident how STBC yield network performance improvement throughout the SNR region but especially at low SNR values (where it matters the most).

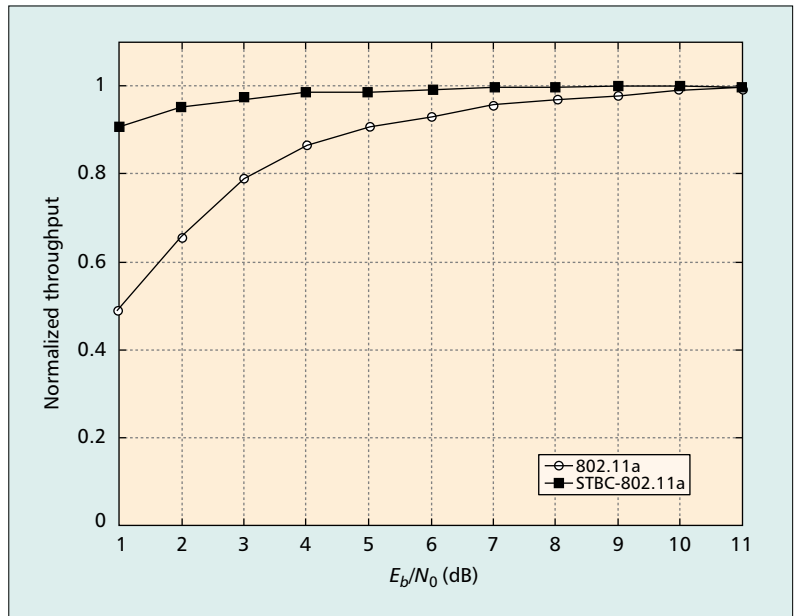

■ Figure 5. Aggregate throughput of five TCP sessions.

## THE GRAPHICAL USER INTERFACE

To make it easier to select among various implementation options and to optimize PHY/network performance, we developed a user-friendly menu-driven STC simulator graphical user interface (GUI) using the MATLAB programming language<sup>8</sup> that works under the Windows and UNIX platforms. A layout of the GUI is depicted in Fig. 6. For an uplink simulation, we can specify the number of STC users, number of transmit antenna per user, and number of receive antennas at the

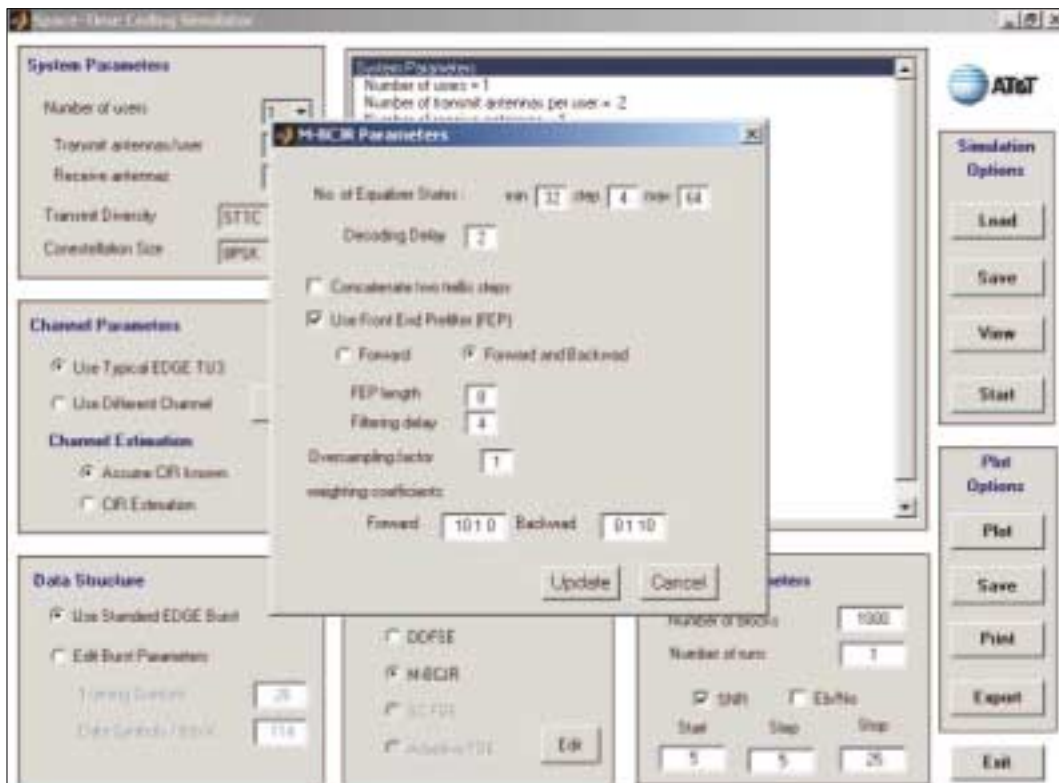

■ Figure 6. Space-time coding graphical user interface layout.

<sup>8</sup> MATLAB is a trademark of Math Works Inc.

Space-time trellis and block codes enjoy rich structure that should be exploited in a multi-user broadband wireless modem to enhance its performance and reduce the complexity of receiver signal processing functions.

base station. For a downlink simulation, we can specify the number of transmit antennas at the base station and the number of receive antennas at the terminal. Other input parameters are the signal constellation type and the transmit diversity scheme. Three forms of transmit diversity can be simulated: delay diversity, STTC, and STBC.

The channel is specified through its power delay profile. The number of information and training symbols in each transmission frame are input parameters to the GUI.

At the receiver end, the GUI can simulate performance under perfect and estimated channel conditions. For the latter, least squares training-based channel estimation is used. When the channel is frequency-selective different joint equalizer/decoder structures can be simulated depending on the transmit diversity scheme used. The user specifies the number of blocks to be transmitted and the SNR range, and the GUI generates a BER plot. **A version of the GUI with pre-set parameters is accessible from <http://www.research.att.com/~naofal/stcsim.htm>**

Overall, our GUI tool enables a wireless network architect to efficiently test the performance of various STC schemes, and thus can lead to improved and accelerated design cycles.

## CONCLUSION

Space-time trellis and block codes enjoy rich structure that should be exploited in a multi-user broadband wireless modem to enhance its performance and reduce the complexity of receiver signal processing functions including channel estimation, joint equalization/decoding, and interference cancellation. The substantial physical layer gains obtained in terms of reduced error rates translate into substantial gains at the networking layer in terms of throughput. These performance and complexity gains are more significant for broadband than for narrowband channels due to the availability of multipath in addition to spatial diversity.

## ACKNOWLEDGMENT

The authors would like to thank S. N. Diggavi, A. F. Naguib, W. Turin, and V. Vaishampayan for many stimulating discussions and for an anonymous reviewer for valuable feedback.

## REFERENCES

- [1] I. Telatar, "Capacity of Multi-Antenna Gaussian Channels," *Euro. Trans. Telecommun.*, Nov. 1999, pp. 585-95.
- [2] V. Tarokh, N. Seshadri, and A.R. Calderbank, "Space-Time Codes for High Data Rate Wireless Communications: Performance Criterion and Code Construction," *IEEE Trans. Info. Theory*, Mar. 1998, pp. 744-65.
- [3] A. Naguib et al., "A Space-Time Coding Modem for High-Data-Rate Wireless Communications," *IEEE JSAC*, Oct. 1998, pp. 1459-77.
- [4] S. Alamouti, "A Simple Transmit Diversity Technique for Wireless Communications," *IEEE JSAC*, Oct. 1998, pp. 1451-58.
- [5] S. Diggavi et al., "Differential Space-Time Transmission for Frequency-Selective Channels," *IEEE Comm. Lett.*, June 2002.
- [6] D. Chu, "Polyphase Codes with Good Periodic Correlation Properties," *IEEE Trans. Info. Theory*, IT-18:531-532, July 1972.
- [7] C. Fragouli, N. Al-Dhahir, and W. Turin, "Reduced-Complexity Training Schemes for Multiple Antenna Broadband Transmissions," *WCNC*, vol. 1, Mar. 2002, pp. 78-83.
- [8] E. Lindskog and A. Paulraj, "A Transmit Diversity Scheme for Delay Spread Channels," *IEEE ICC*, June 2000, pp. 307-11.

- [9] L. Bahl et al., "Optimal Decoding of Linear Codes for Minimizing Symbol Error Rate," *IEEE Trans. Info. Theory*, vol. 20, Mar. 1974, pp. 284-87.
- [10] C. Fragouli et al., "Prefiltered M-BCJR Equalizer for Frequency Selective Channels," *Conf. Info. Sci. Sys.*, Mar. 2001, pp. 841-45.
- [11] N. Al-Dhahir, "Single-Carrier Frequency-Domain Equalization for Space-Time Block Coded Transmissions over Frequency-Selective Fading Channels," *IEEE Commun. Lett.*, July 2001, pp. 304-6.
- [12] H. Sari, G. Karam, and I. Jeanclaude, "Transmission Techniques for Digital Terrestrial TV Broadcasting," *IEEE Commun. Mag.*, Feb. 1995, pp. 100-9.
- [13] A. F. Naguib, N. Seshadri, and A. R. Calderbank, "Applications of Space-Time Block Codes and Interference Suppression for High Capacity and High Data Rate Wireless Systems," *32nd Asilomar Conf. Sig., Sys. Comp.*, 1998, pp. 1803-10.
- [14] A. Stamoulis and N. Al-Dhahir, "802.11 Network Throughput Gains Due to Space-Time Block Codes," *Conf. Info. Sci. Sys.*, Mar. 2002.
- [15] H. Balakrishnan et al., "Comparison of Mechanisms for Improving TCP Performance over Wireless Links," *IEEE/ACM Trans. Net.*, Dec. 1997, pp. 756-69.

## BIOGRAPHIES

NAOFAL AL-DHAHIR [SM] (naofal@research.att.com) received his M.S. and Ph.D. degrees from Stanford University in 1990 and 1994, respectively, in electrical engineering. He was an instructor at Stanford University during winter 1993. From August 1994 to July 1999, he was a member of technical staff at the Communications Program at GE Corporate R&D Center in Schenectady, New York, where he worked on various aspects of satellite communication systems design and anti-jam GPS receivers. Since August 99, he has been a principal member of technical staff at AT&T Shannon Laboratory in Florham Park, New Jersey. His current research interests include equalization schemes, space-time coding and signal processing, OFDM, and digital subscriber line technology. He has authored around 45 journal papers and holds 7 U.S. patents in the areas of satellite communications and digital television. He is a member of the IEEE SP4COM technical committee.

CHRISTINA FRAGOULI (M '00) received his B.S. degree in electrical engineering from the National Technical University of Athens, Athens, Greece, in 1996, and his M.Sc. and Ph.D. degrees in electrical engineering from the University of California at Los Angeles in 1998 and 2000, respectively. From September 2000 to September 2001, she was with AT&T Shannon Laboratory, Florham Park, as a consultant. She is currently a research associate at the National Capodistrian University of Athens. Her research interests are in the area of channel coding and signal processing for communications.

ANASTASIOS STAMOULIS holds degrees in computer engineering (Diploma, University of Patras, Greece, July 1995), computer science (Master, University of Virginia, May 1997), and electrical engineering (Ph.D., University of Minnesota, December 2000). His research interests include wireless networking, QoS networks, digital communications, and digital signal processing.

WALEED M. YOUNIS received his B.S. and M.S. degrees in electrical engineering from Ain Shams University, Cairo, in 1995 and 1998, respectively. Since September 1999, he has been pursuing a Ph.D. degree in electrical engineering at UCLA. His research interests include adaptive filtering, equalization for wireless communications and MIMO communication systems.

ROBERT CALDERBANK [F] is vice president for research at AT&T. He is also responsible for directing the research program in Internet and networking systems. This program provides AT&T with technical and industry leadership in all areas of networking technology. These areas include network security, content distribution, operations support, network measurement and management, and end-to-end optical systems. He is an AT&T Fellow, and a recipient of the IEEE Third Millennium Medal for his contributions to digital communications. These include the design of high-speed voiceband modems, the development of advanced read channels for magnetic disk storage, and the invention of space-time codes, a breakthrough wireless technology that uses a small number of antennas to significantly improve throughput and reliability.